

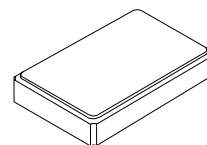



# Preliminary

**XTL1028N**

**30.00000 MHz  
Crystal Unit**



**SM5032-4 Case**

- **Surface Mount Seam-Weld Package**
- **Good Frequency Stability over Temperature**
- **Excellent Reliability**
- **Complies with Directive 2002/95/EC (RoHS)** 

The XTL1028N is a surface mount 5.0 x 3.2 mm crystal unit for use in wireless telecommunications devices, especially where an ultra-miniature package is needed for mobility.

## Electrical Characteristics

Characteristic	Sym	Notes	Minimum	Typical	Maximum	Units
Nominal Frequency				30.00000		MHz
Mode of Oscillation				Fundamental		
Storage Temperature Range, Crystal Only			-50		+125	°C
Storage Temperature Range, in Tape and Reel			-40		+85	°C
Operating Temperature Range			-40		+85	°C
Frequency Stability over Operating Temperature Range			±20 ppm (referenced to the value at 25°C)			
Frequency Make Tolerance	F <sub>L</sub>		±20 ppm @ 25°C ±3°C			
Equivalent Series Resistance	ESR				60	Ω
Shunt Capacitance	C <sub>O</sub>				5.0	pF
Nominal Drive Level				10	100	μW
Load Capacitance	C <sub>L</sub>			12.0		pF
Insulation Resistance at 100 VDC			500			MΩ
Weight			0.037 ±0.005			gm
Standard Shipping Quantity on 330 mm (13") Reel				3000		units
Lid Symbolization (in addition to Lot and/or Date Codes)			1028 <u>YWWS</u>			

**Crystal Equivalent Circuit**

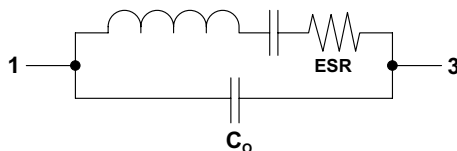

**CAUTION: Electrostatic Sensitive Device. Observe precautions for handling.**

### Notes:

1. US and international patents may apply.
2. The design, manufacturing process, and specifications of this device are subject to change without notice.
3. RFM, stylized RFM logo, and RF Monolithics, Inc. are registered trademarks of RF Monolithics, Inc.

# SM5032-4 Case

## 4-Terminal Surface-Mount Seam Weld Case 5.0 x 3.2 mm Nominal Footprint

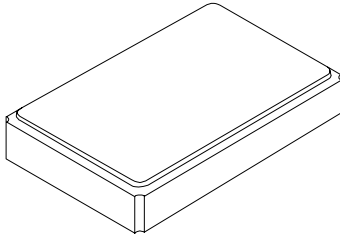

**Top View**

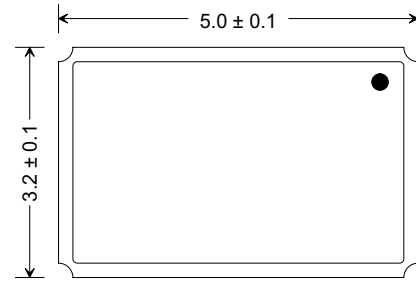

Dot indicates Pin 3 location

**Side View**

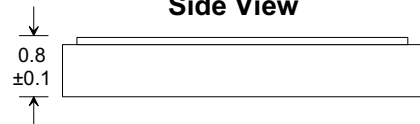

**Bottom View**

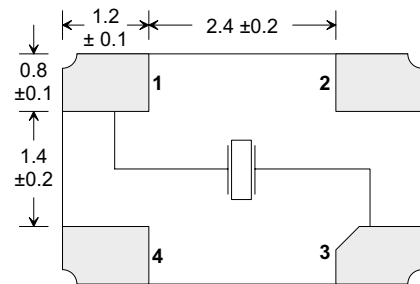

Pins 2 and 4 are connected to the lid

Dimensions are in mm

**Electrical Connections**

Pin	Connection
1	I/O
2	GND (lid)
3	I/O
4	GND (lid)

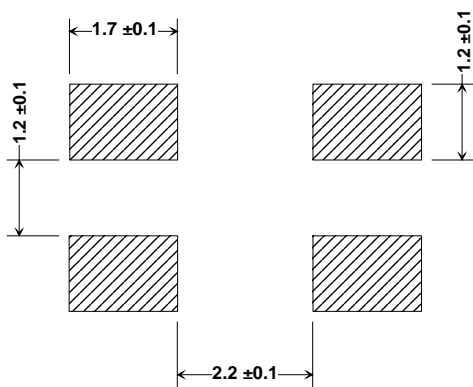

**Footprint (mm)**

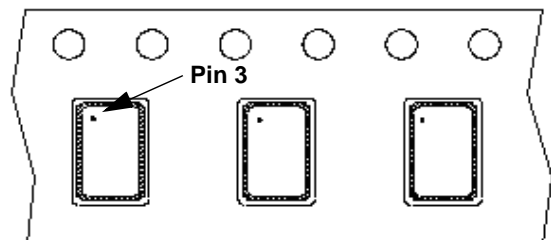

**Package Orientation in Carrier Tape**

# Reel Dimensions

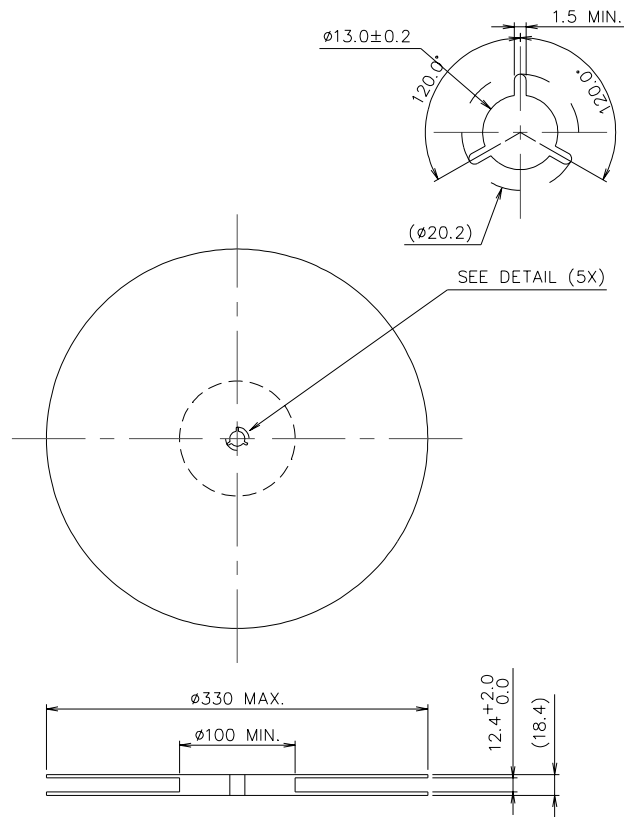

# Tape Dimensions

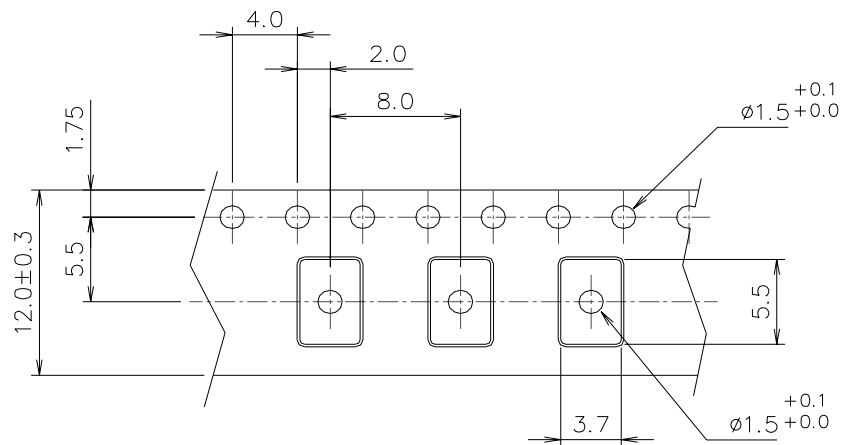

## Notes:

1. Unless otherwise specified, tolerance on dimensions is  $\pm 0.1$  mm
2. Material is black conductive polystyrene
3. 10 pitch cumulative tolerance is  $\pm 0.2$  mm

---

## Typical Reflow Profile

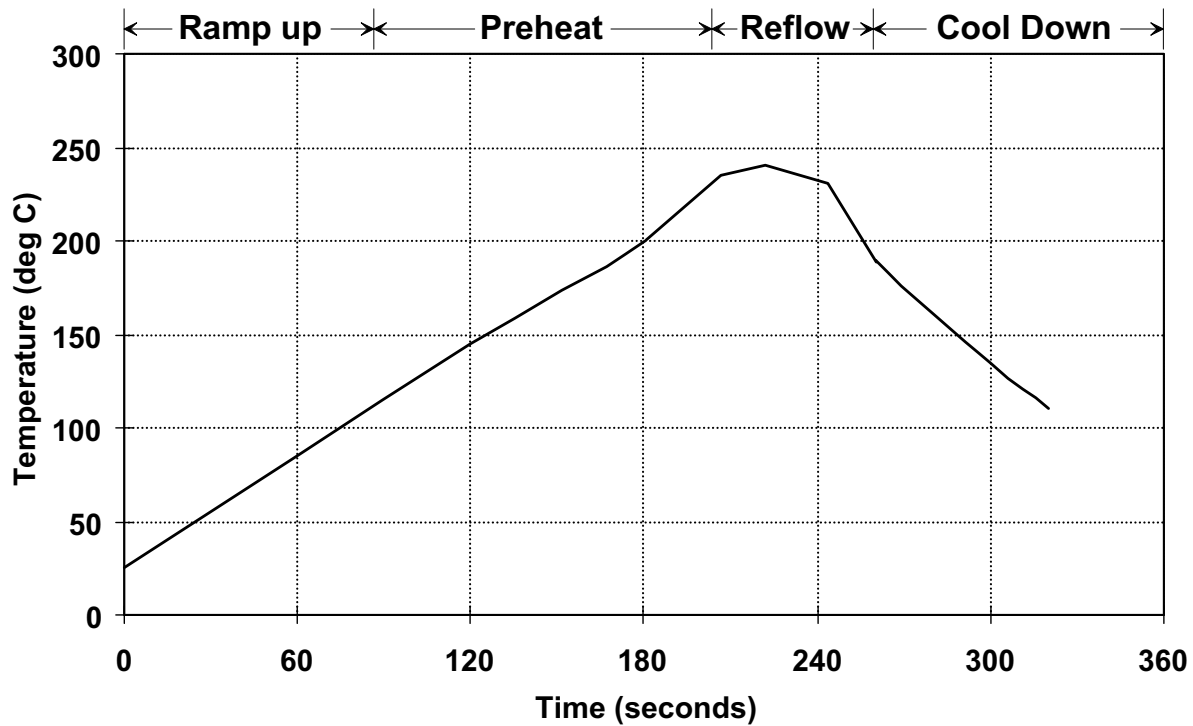

### Notes:

1. Maximum peak temperature: 265 degrees C for 8 to 12 seconds
2. Typical reflow temperature:  $217 \pm 5$  degrees C for 90 to 100 seconds