

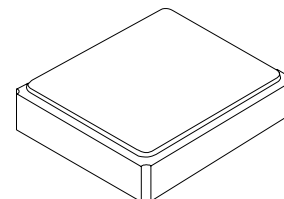

XTL1021P

**16.000000 MHz
Crystal Unit**



SM3225-4 Case

- High Performance Crystal for Wireless Communications Devices
- Excellent Frequency Stability and Reliability
- Ultra-miniature Surface Mount Seam Weld Package
- Complies with Directive 2002/95/EC (RoHS)



The XTL1021P is a high stability 16.000000 MHz crystal suitable for a wide range of communications applications where very small size is important.

Electrical Characteristics

Characteristic	Sym	Notes	Minimum	Typical	Maximum	Units
Nominal Frequency	F_O			16.000000		MHz
Mode of Oscillation			Fundamental			
Storage Temperature Range in Tape and Reel			-40		+85	°C
Operating Temperature Range			-20		+70	°C
Frequency Stability over Operating Temperature Range			±10 ppm (referred to the value at 25 °C)			
Frequency Make Tolerance	F_L		±10 ppm @ 25 °C ±3 °C			
Equivalent Series Resistance	ESR				60	Ω
Shunt Capacitance	C_O				3	pF
Nominal Drive Level					10	μW
Load Capacitance	C_L			12		pF
Aging			±1.0 ppm/year @ 25 °C			
Insulation Resistance			500			MΩ
Standard Shipping Quantity on 178 mm (7") Reel				3000		units
Lid Symbolization			1021P YWWS			

Crystal Equivalent Circuit

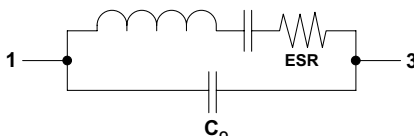

CAUTION: Electrostatic Sensitive Device. Observe precautions for handling.

Notes:

1. US and international patents may apply.
2. The design, manufacturing process, and specifications of this device are subject to change without notice.
3. RFM, stylized RFM logo, and RF Monolithics, Inc. are registered trademarks of RF Monolithics, Inc.

4-Terminal Surface-Mount Seam Weld Case

3.2 x 2.5 mm Nominal Footprint

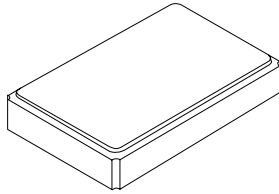

Internal Connections
{Top View}

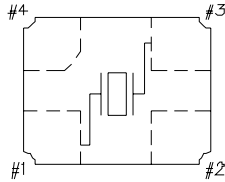

#2, #4 is connected with a cover

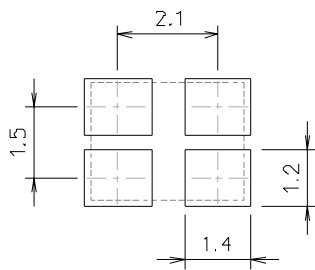
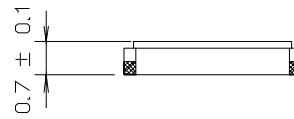
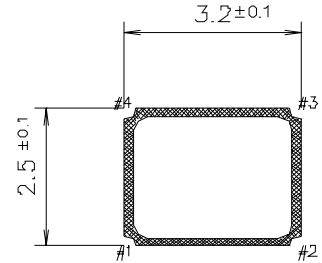

PCB Footprint (mm)

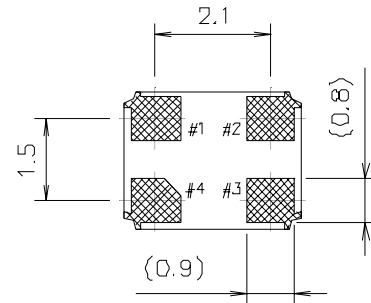

Package Dimensions

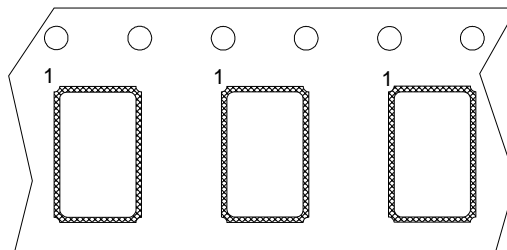

Package Orientation in Carrier Tape

Reel Dimensions

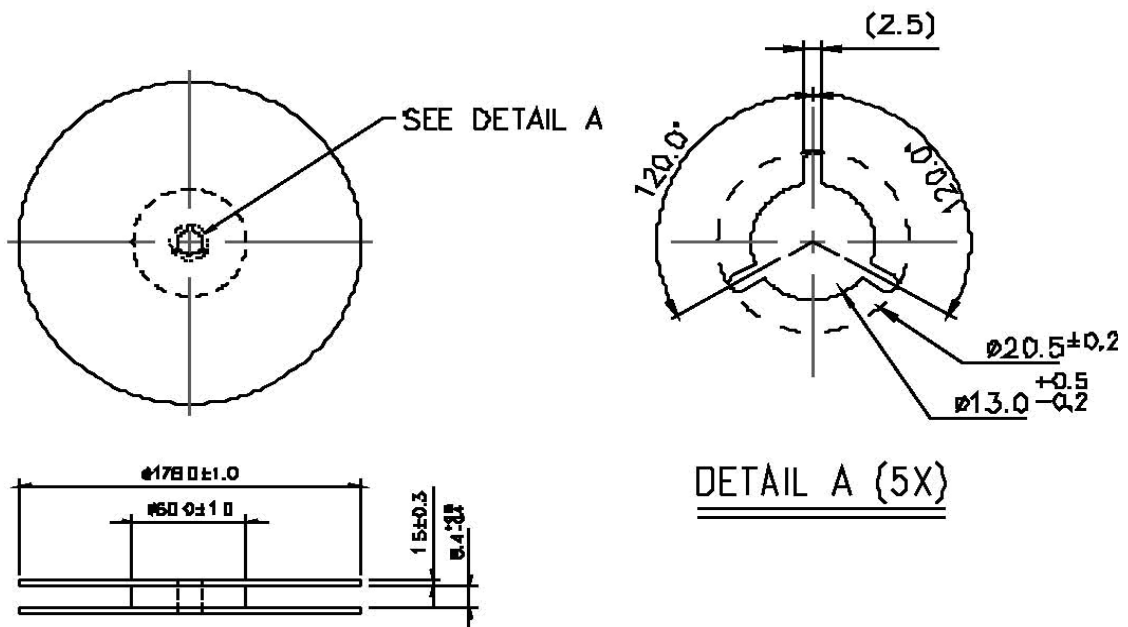

Tape Dimensions

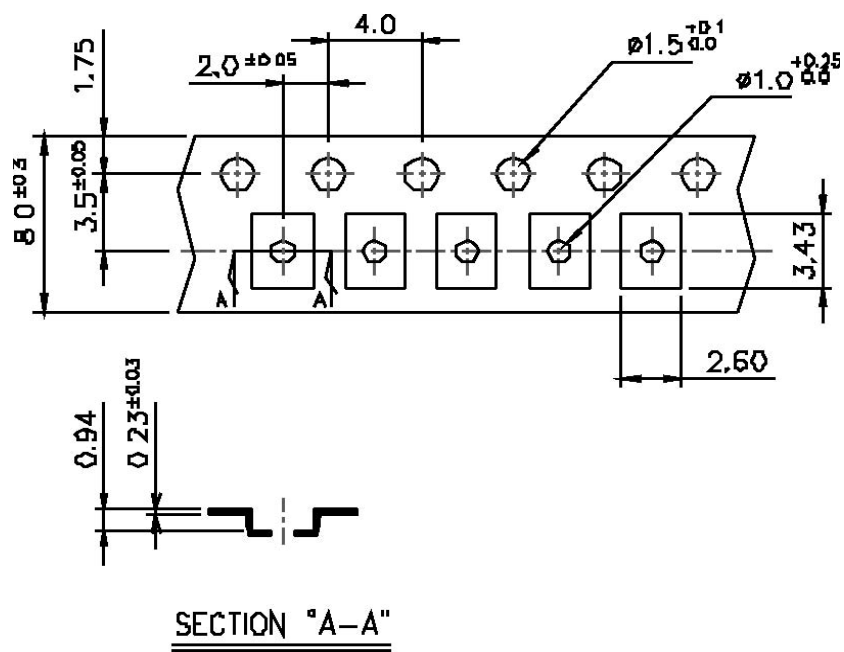

Typical Solder Reflow Profile

