

ASH Transceiver Software Designer's Guide

Updated 2002.08.07



ASH Transceiver Software Designer's Guide

1 Introduction

- 1.1 Why Not Just Use a UART?
- 1.2 The Radio Channel – Magic and Imperfect
 - 1.2.1 Modeling a radio system
 - 1.2.2 Data rate and bandwidth
 - 1.2.3 Noise and interference
 - 1.2.4 Indoor RF propagation
 - 1.2.5 Regulatory considerations

2 Key Software Design Issues

- 2.1 Fail-Safe System Design
- 2.2 Message Encoding for Robust RF Transmission
- 2.3 Clock and Data Recovery
- 2.4 Communication Protocols
 - 2.4.1 Digital command transmissions
 - 2.4.2 Data transmissions using packet protocols

3 IC1000 “Radio UART”

- 3.1 IC1000 Description
- 3.2 IC1000 Application

4 Example Data Link Layer Protocol

- 4.1 Link Layer Protocol Source Code
- 4.2 Terminal Program Source
- 4.3 Variations and Options
- 4.4 Test Results

5 Source Code Listings

- 5.1 DK200A.ASM
- 5.2 V110T30C.FRM
- 5.3 DK110K.ASM
- 5.4 V110T05B.FRM

6 Revisions and Disclaimers

Drawings

Figure 1.2.1	Radio System Model
Figure 1.2.2	Receiver Signal Processing
Figure 1.2.3.1	Noise Amplitude Probability Distribution
Figure 1.2.3.2	Signal Reception with No Noise
Figure 1.2.3.3	Signal Reception with Moderate Noise
Figure 1.2.3.4	Signal Reception with Heavy Noise
Figure 1.2.3.5	Reception with Heavy Noise (expanded scale)
Figure 2.2.1	Noise Reception with No Signal and No Threshold
Figure 2.2.2	Signal Reception with No Signal and Moderate Threshold
Figure 2.4.1	ASH Receiver Application Circuit – Keyloq Configuration
Figure 3.2.1	Typical IC1000 Application
Figure 4.1	ASH Transceiver Application Circuit – Low Data Rate OOK
Figure 4.2	Radio Board Modification Detail
Figure 4.3	Jumper Pin Detail
Figure 4.4	Packet and Byte Structure Details

1 Introduction

1.1 Why Can't I Just Use a UART?

Why can't I just use a UART and a couple of transistors to invert the TX and RX data signals to and from your ASH transceiver and get my application on the air? Well, you can if you don't need maximum performance and you make the necessary provisions in your software for the characteristics of radio communications. But, you are going to leave a lot of performance on the table. A radio link is a type of communication channel, and it has specific properties and characteristics, just as an ordinary phone line is another type of communication channel with its own properties and characteristics. To get usable data communications over your phone line, you place a modem between your PC's UART and the phone line. And to get good performance from your ASH radio link, you are going to need to put something more than a couple of transistors between the UART and the transceiver.

1.2 The Radio Channel – Magic and Imperfect

Radio is magic. It allows commands, data, messages, voice, pictures and other information to be conveyed with no physical or visible connection. A radio wave can penetrate most materials, and it can get around most barriers it cannot directly penetrate. It is arguably the most useful electronic communication channel so far discovered.

But from a software developer's point of view, a radio channel has some aggravating properties and characteristics. The good news is there are strategies for dealing with them.

1.2.1 Modeling a radio system

Figure 1.2.1 is a block diagram of a radio system. The antenna on the transmitter launches energy into the RF channel, and the antenna on the receiver retrieves some of the energy and amplifies it back to a useful level. No big deal, right? Well its no small deal either.

Radio System Model



Figure 1.2.1

Receiver Signal Processing

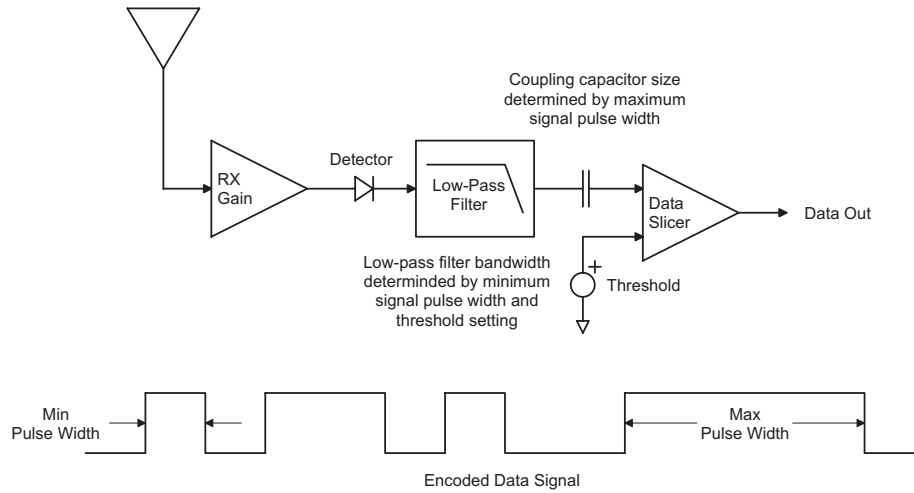

Figure 1.2.2

1.2.2 Data rate and bandwidth

Figure 1.2.2 is a generic block diagram of an RF receiver. This is where most of the action takes place in a radio communication system. There are two filters in this block diagram that you need to know about before you start writing code. The low-pass filter limits the rate that data can be sent through the radio system. And it also has a major impact on the range of the system. As you probably guessed, there is a trade-off here. For a fixed amount of transmitter power, you can transmit farther if you transmit at a lower data rate. The coupling capacitor in the block diagram creates a high-pass filter (in other words, your signal is AC coupled). You have to choose a data rate and use a data encoding scheme that lets your information flow successfully through these two filters. And if you get this right, these filters will greatly contribute to the overall performance of your system.

It is best to think in terms of the most narrow pulse (or most narrow gap) in your encoded signal, which must match the bandwidth of the low-pass filter, and the widest pulse in your encoded signal (or the widest gap), which must correctly match the time constant formed by the coupling capacitor and its associated circuitry. It is the minimum and maximum pulse widths (and gaps) in the encoded data that must be “in tune” with the filters in the receiver – not the underlying data rate.

1.2.3 Noise and interference

Unlicensed radio regulations, such as FCC regulation 15.249, limit the amount of RF power you can transmit to roughly 0.001% of the power dissipated in a 25 watt light bulb. But you only need to capture about 0.00000002% of this transmitted power level to receive properly encoded data at 2000 bps under typical conditions. Using decent antennas chest-high above the ground, this equates to more than one-eighth of a mile of range outdoors and much farther if one or both ends of the system are elevated.

There is a limit on how weak an RF signal can get and still convey information. This limit is due to electrical noise. One source of noise is everywhere present on the surface of the earth and is due to thermally-generated random electrical voltages and currents. Any device with electrical resistance becomes a source of this noise. Two other noise contributors are important in RF communications – semiconductor noise and attenuation. Semiconductor devices such as RF amplifiers contain noise generation mechanisms in addition to resistive thermal noise. Also, any component that attenuates a signal and is a thermal noise generator itself reduces the signal-to-noise ratio by the amount of the attenuation. An RF filter is an example of this type of component.

A signal transmitted through a radio system will be at its lowest power level when it reaches the first amplifier stage in the receiver. The noise added to the signal at this point places an upper limit on the signal-to-noise ratio that can be achieved by the receiver (for a given low-pass filter bandwidth). A good antenna helps keep the signal-to-noise ratio up by delivering more signal power. In addition, using a low-loss RF filter between the antenna and the first amplifier helps keep the signal-to-noise ratio up by minimizing signal attenuation. Using RF IC technology with low inherent RF semiconductor noise minimizes the amount of noise that is added to the signal beyond the ever-present resistive thermal noise. And yes, there are software tricks to take maximum advantage of whatever signal-to-noise ratio the hardware guys get for you.

Figure 1.2.3.1 shows the probability distribution, or histogram, of the noise voltage you would see at the base-band output of the ASH transceiver ($R_{LPF} = 330 \text{ K}$). Notice that the noise has a Gaussian probability distribution. About 70% of the time the noise voltage will be between $\pm 9 \text{ mV}$, or one standard deviation. Occasionally, noise spikes will reach $\pm 18 \text{ mV}$, or two standard deviations. On rare occasions, spikes will reach $\pm 27 \text{ mV}$, and on very rare occasions noise spikes will reach $\pm 36 \text{ mV}$ or more. So every now and then a noise spike or “pop” will occur that is strong enough to corrupt even a strong received signal. This characteristic of thermal noise (and thermal-like semiconductor noise) means that no RF channel can be perfectly error free. You have to plan for data transmission errors when designing your software.

From DC to frequencies much higher than RF, thermal noise exhibits a flat power spectrum. The power spectrum of semiconductor noise can also be considered flat across the RF bandwidth of a typical receiver. If you halve the bandwidth of the low-pass filter in a receiver, you halve the thermal noise power that comes through it. This is why you can transmit longer distances at a lower data rate. It allows you to reduce the bandwidth of

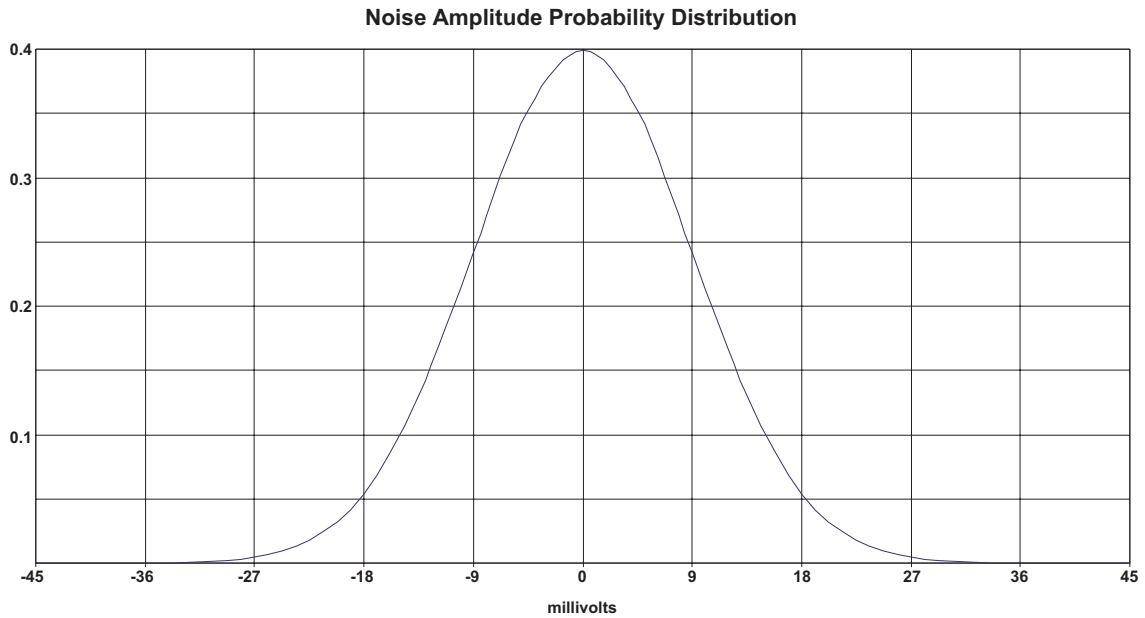

Figure 1.2.3.1

the low-pass filter so less noise gets through. You can then successfully recover data from a weaker received signal.

Lets go back and look at Figure 1.2.2 again. The job of the data slicer is to convert the signal that comes through the low-pass filter and coupling capacitor back into a data stream. And when everything is set up properly, the data slicer will output almost perfect data from an input signal distorted with so much noise that it is hard to tell there is a signal there at all. For the time being, assume the threshold voltage to the data slicer is zero. In this case, anytime the signal applied to the data slicer is zero volts or less, the data slicer will output a logic 0. Anytime the signal is greater than zero volts, the data slicer will output a logic 1. Through software techniques, you can assure that the signal reaching the data slicer swings symmetrically about 0 volts. Noise spikes, either positive or negative, that are slightly less than one half of the peak-to-peak voltage of the desired signal will not appear as spikes in the data output. The ability to recover almost perfect data from a signal with a lot of added noise is one of the main reasons that digital has overtaken analog as the primary format for transmitting information.

In the way of a preview, look at Figures 1.2.3.2, 1.2.3.3, 1.2.3.4 and 1.2.3.5, which are simulations of a radio system with various amounts of noise added to the signal. The top trace in Figure 1.2.3.2 is the signal seen at the input to the data slicer.

The horizontal line through this signal is the slicing level. Notice that the signal droops down as it starts from left to right, so that is swinging symmetrically around the slicing level by about the fifth vertical grid line. This is the transient response of the base-band coupling capacitor, and its associated circuitry, as it starts blocking the DC component of the received signal. The steady 1-0-1-0... bit pattern seen to the left of the fifth grid line is a training preamble. It sets up the slicing symmetry. To the right of the fifth grid line there is a 12 bit start symbol and then the encoded message bits, etc. You will notice that

Signal Reception with No Noise

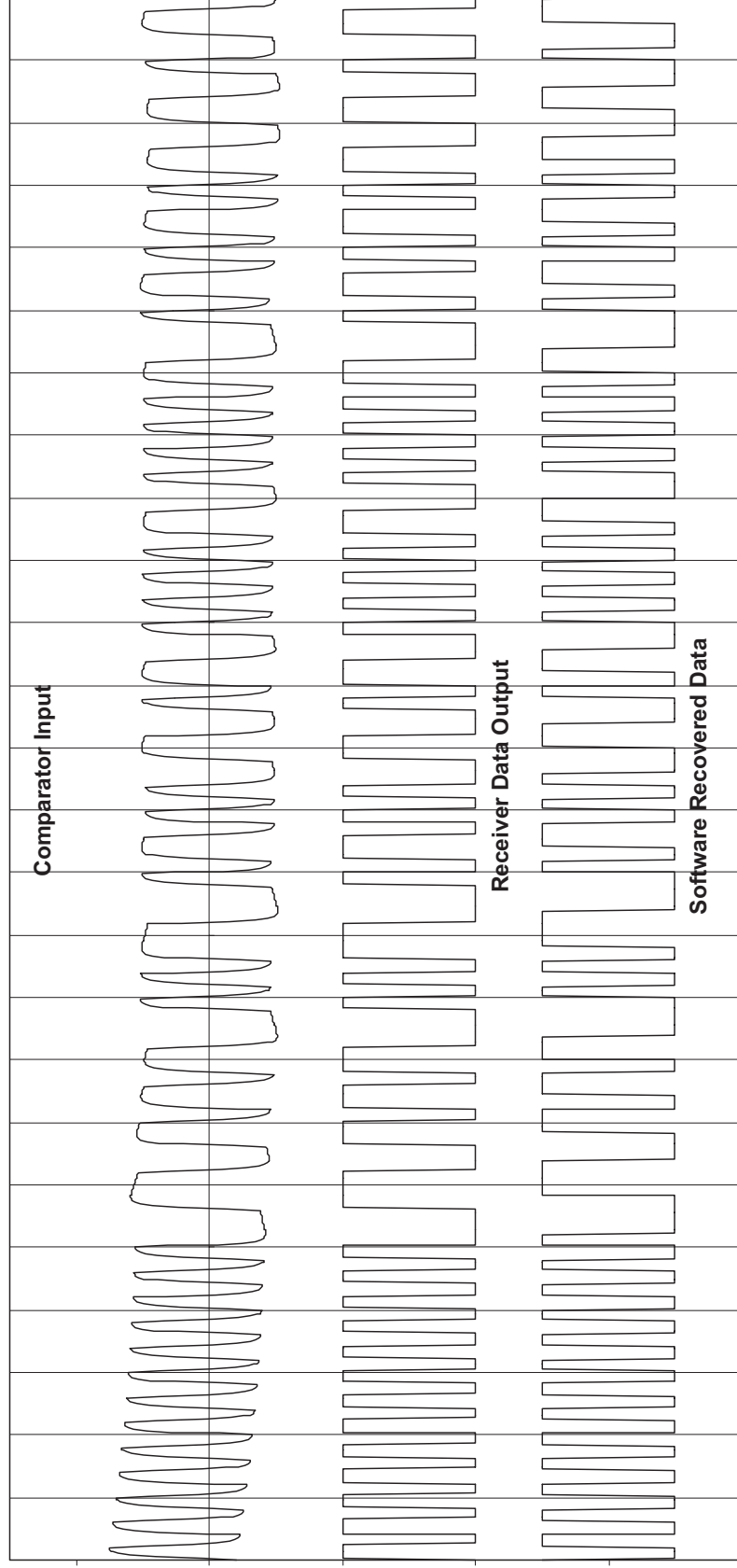

Figure 1.2.3.2

Signal Reception with Moderate Noise

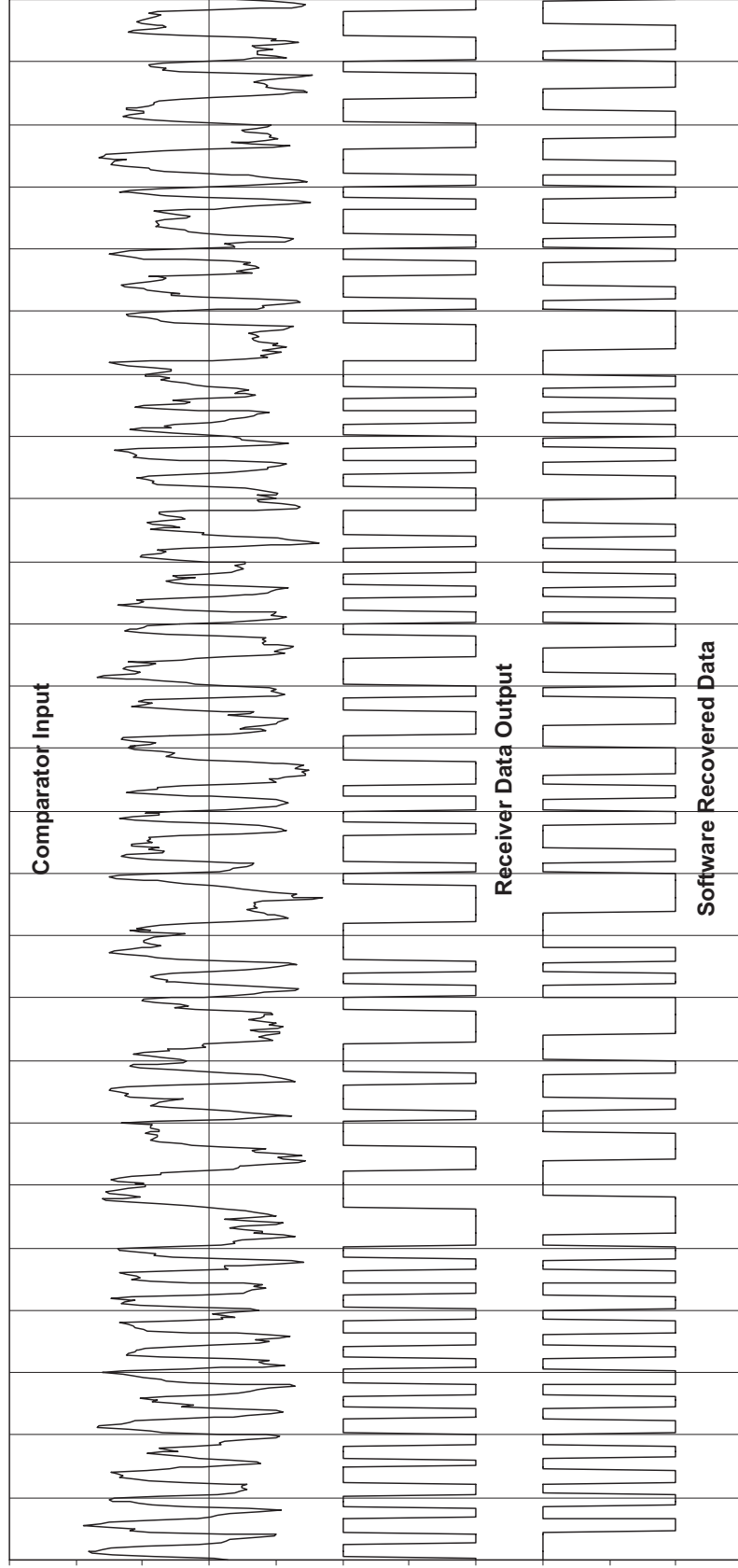

Figure 1.2.3.3

Signal Reception with Heavy Noise

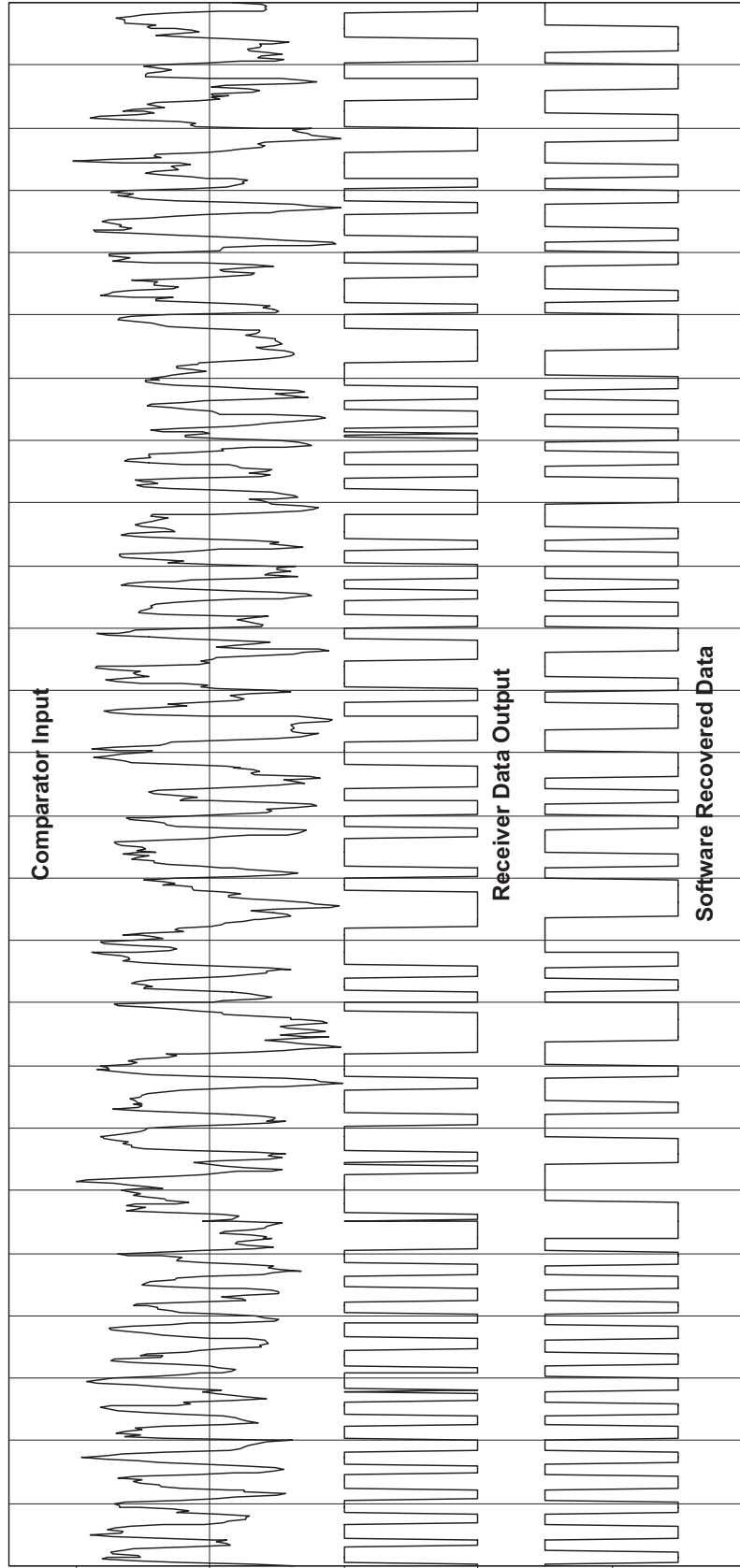

Figure 1.2.3.4

**Reception with Heavy Noise
(expanded scale)**

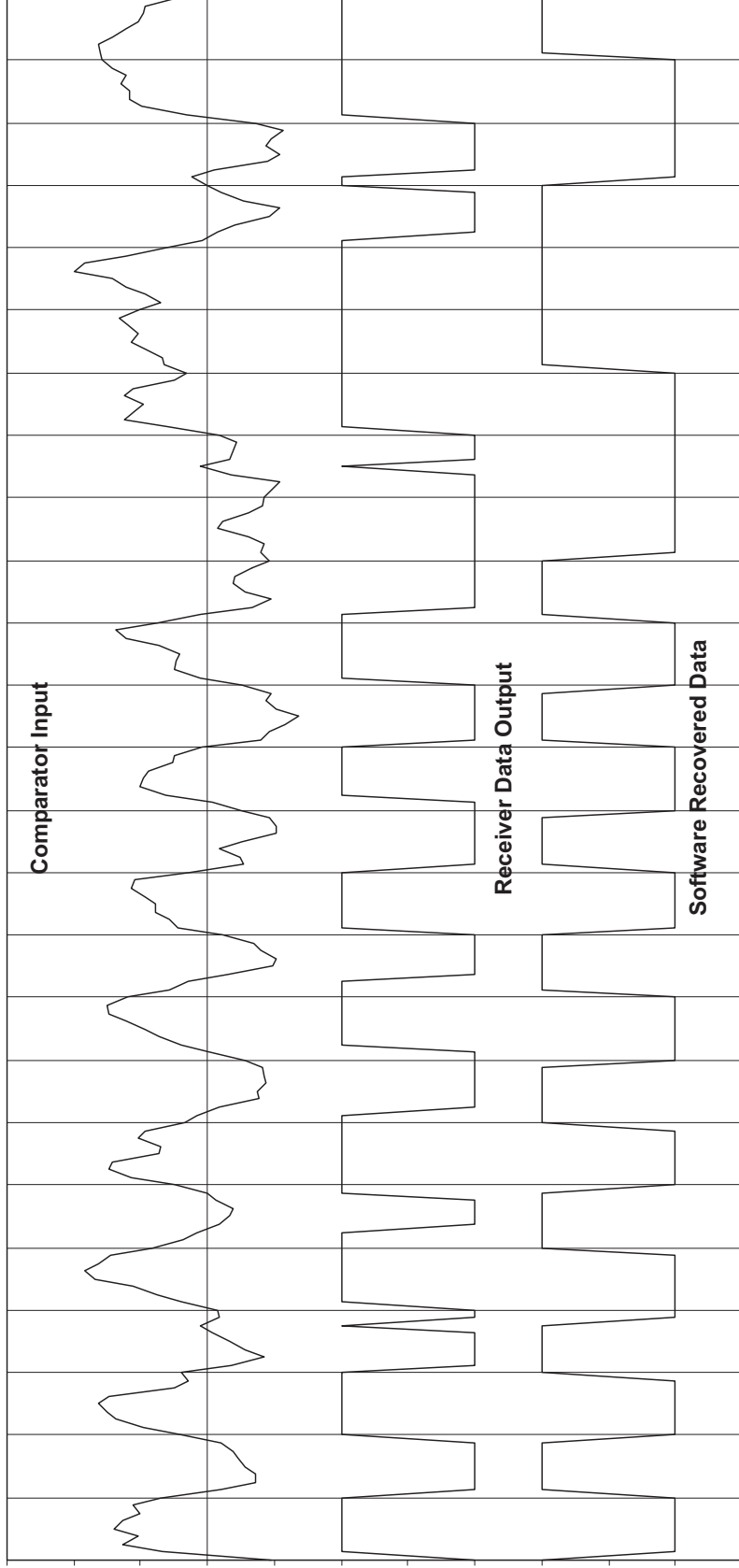

Figure 1.2.3.5

the signal has been “rounded off” so that the 1-0-1-0... bit sequences almost look sinusoidal. This shaping effect is due to the low-pass filter. If you set the bandwidth of the filter too low for a given data rate, it will start seriously reducing the amplitude of these 1-0-1-0... bit sequences and/or smearing them into each other.

The output of the data slicer is the middle trace, and the output of the software recovery subroutine is the bottom trace. Notice that the bottom trace is shifted to the right one bit period. This is because the software “studies” the receiver data output for a complete bit period before estimating the bit value. It will soon become apparent why this is done.

Figure 1.2.3.3 shows the same signal with a moderate amount of noise added. You now have to look at the top trace carefully to see the data pattern (look right at the slicing level). The middle trace shows the output of the data slicer, which has recovered the data accurately other than for some jitter in the width of the bits. The data recovered by the software matches the middle trace again, shifted one bit period to the right.

Figure 1.2.3.4 shows the signal with heavy noise added. The data pattern has become even more obscure in the top trace. With this much noise, the output from the data slicer shows occasional errors. Note that the software subroutine has been able to overcome these errors by deciding the most likely bit value at the end of each bit period. Figure 1.2.3.5 is a section of 1.2.3.4 on an expanded scale to show more bit-by-bit detail.

Interference is defined as an unwanted RF signal radiated by another system (RF or digital). Like noise, interference that is not too strong can be eliminated by the data slicer and/or software subroutine. Of course, the data has to be encoded so that it swings symmetrically around the slicing level to get maximum noise and interference rejection.

1.2.4 Indoor RF propagation

It is intuitive that the farther away from a transmitter you get, the less power you can capture from it with your receiver. This is what you would see in free space, far away from the ground and other physical objects. But on the ground, and especially indoors, you will find that the signal strength varies up and down rapidly as the distance between the transmitter and the receiver is steadily increased. The reason this happens is both good news and bad news. It turns out that the radio waves from the transmitter antenna are taking many different paths to the receiver antenna. Radio waves strongly reflect off the ground and off metal surfaces as light reflects off a mirror. And radio waves will also partially reflect off non-metallic walls, etc. as light does off a window pane. The good news is that all this bouncing around allows radio waves to diffuse around barriers they cannot directly penetrate. The bad news is that all the bouncing around makes the RF power you receive vary rapidly (flutter) as you move around and hit small reception “dead spots”. You can even see reception flutter if you stand still and other people, vehicles, etc. move nearby. Any radio system that operates near the ground (mobile phones, wireless microphones, broadcast radios in cars, etc.) must deal with this multi-path flutter problem. And yes, it is a consideration when you start writing your code.

Studies on indoor propagation show that you will find only a few spots in a room that have really bad reception, and these severe “dead spots” tend to occupy a very small space. Mild dead spots are far more common, and you will also find some places where reception is especially good. As a rule of thumb, you need 100 times more transmitted power indoors than in free space to get adequate reception at comparable distances. This is called a 20 dB fading margin, and it provides about 99% coverage indoors. If you are in a severe dead spot at UHF frequencies, moving just an inch or two gets you out of it.

When you look at a professional wireless microphone, you will notice that the base unit is equipped with a “rabbit ear” antenna. Actually, there are two separate antennas and two separate receivers in the wireless microphone base unit, with the antennas at right angles to each other. This arrangement provides diversity reception, which greatly mitigates the dead spot problem indoors. Since the paths between the two base station antennas and the microphone are different, it is unlikely that the microphone will hit a dead spot for both antennas at the same time. Mobile phone base stations also use diversity reception as do many other radio systems, including a number of ASH transceiver systems.

1.2.5 Regulatory considerations

Systems based on ASH transceiver technology operate under various low power, unlicensed UHF radio regulations. From a software point of view, the main differences in these regulations are the maximum power you are allowed to transmit, and the allowed transmitter duty cycle. European regulations (ETSI) allow the most transmitted power, American regulations are in the middle, and Japan allows the least transmitted power. At lower power levels, you have to transmit at a low data rate to get a useful amount of range. At higher power levels you have more flexibility.

Duty cycle refers to the percentage of time each transmitter in your system can be on. Some regulations, such as FCC 15.249 place no restrictions on duty cycle. Some bands in Europe also have no current duty cycle limit - for example, the 433.92 MHz band. Other bands in Europe do have a duty cycle limit. At 868.35 MHz, the duty cycle limit is 36 seconds in any 60 minute interval. Duty cycle requirements influence the choice of band to operate in, and the design of your software. RFM’s web site has links to many radio regulatory sites. Be sure to thoroughly familiarize yourself with the regulations in each geographical market for your product. We have seen cases where a customer had to redo a well-engineered system to accommodate a regulatory subtlety.

2 Key Software Design Issues

There are at least four key issues to consider in designing ASH transceiver software. You may identify others depending on the specifics of your product’s application. It is worth giving it some thought before you start designing your code.

2.1 Fail-Safe System Design

Most unlicensed UHF radio systems operate with few interference problems. However, these systems operate on shared radio channels, so interference can occur at any time and at any place. Products that incorporate unlicensed UHF radio technology must be designed so that *a loss of communications due to radio interference or any other reason will not create a dangerous situation, damage equipment or property, or cause loss of valuable data*. The single most important consideration in designing a product that uses unlicensed radio technology is safety.

2.2 Message Encoding for Robust RF Transmission

Look at Figure 1.2.2 again, and note the threshold input to the data slicer. When you set the threshold voltage to a value greater than zero you move the slicing level up. This provides a noise squelching action. Compare Figures 2.2.1 and 2.2.2. In Figure 2.2.1, the threshold is set to zero. With no signal present, noise is continuously present at the receiver data output, and at the output of the software data recovery routine. Software downstream of the data recovery subroutine has to be able to distinguish between noise and a desired signal. Figure 2.2.2 shows the effect of adding a moderate threshold. Notice that just a few noise spikes appear at the receiver data output and no noise spikes come out of the software data recovery routine (it could still happen occasionally). As we raise the threshold more, even fewer noise spikes will appear at the receiver data output. Don't expect to eliminate all noise spikes – noise amplitude has that Gaussian probability distribution we discussed earlier. Even using a very heavy threshold, you have to plan for noise spikes now and then, as well as strong bursts of interference.

As you raise the threshold from zero, you reduce the receiver's sensitivity to desired signals, and you make it more vulnerable to propagation flutter. If you need all the range and system robustness possible, you will want to use little or no threshold. On the other hand, using a threshold can reduce the amount of work your software has to do on data recovery. This allows you to support a higher data rate with the same processing power, or reduce average processor current consumption in applications where this is critical. If you decide to use an ordinary UART on the radio side, a strong threshold is a must. Also, some remote control decoder chips will not tolerate much noise.

The ASH transceiver is equipped with two thresholds, DS1 and DS2. DS1 works basically as shown in Figures 1.2.2, 2.2.1, and 2.2.2. DS2 is used in conjunction with DS1 and its primary job is to support high data rate transmissions. The details on how to adjust these thresholds are given in the ASH Transceiver Designer's Guide, Sections 2.7.1 and 2.7.2.

Your message encoding strategy and several adjustments on the ASH transceiver depend on whether you use a threshold, and on how strongly the threshold is set. Let's start with the "no threshold" case, which offers the best potential performance. Referring to Figure 1.2.3.2, we start the transmission with a 1-0-1-0... training preamble. This preamble needs to be long enough to establish good signal slicing symmetry at the input to the

Noise Reception with No Signal and No Threshold

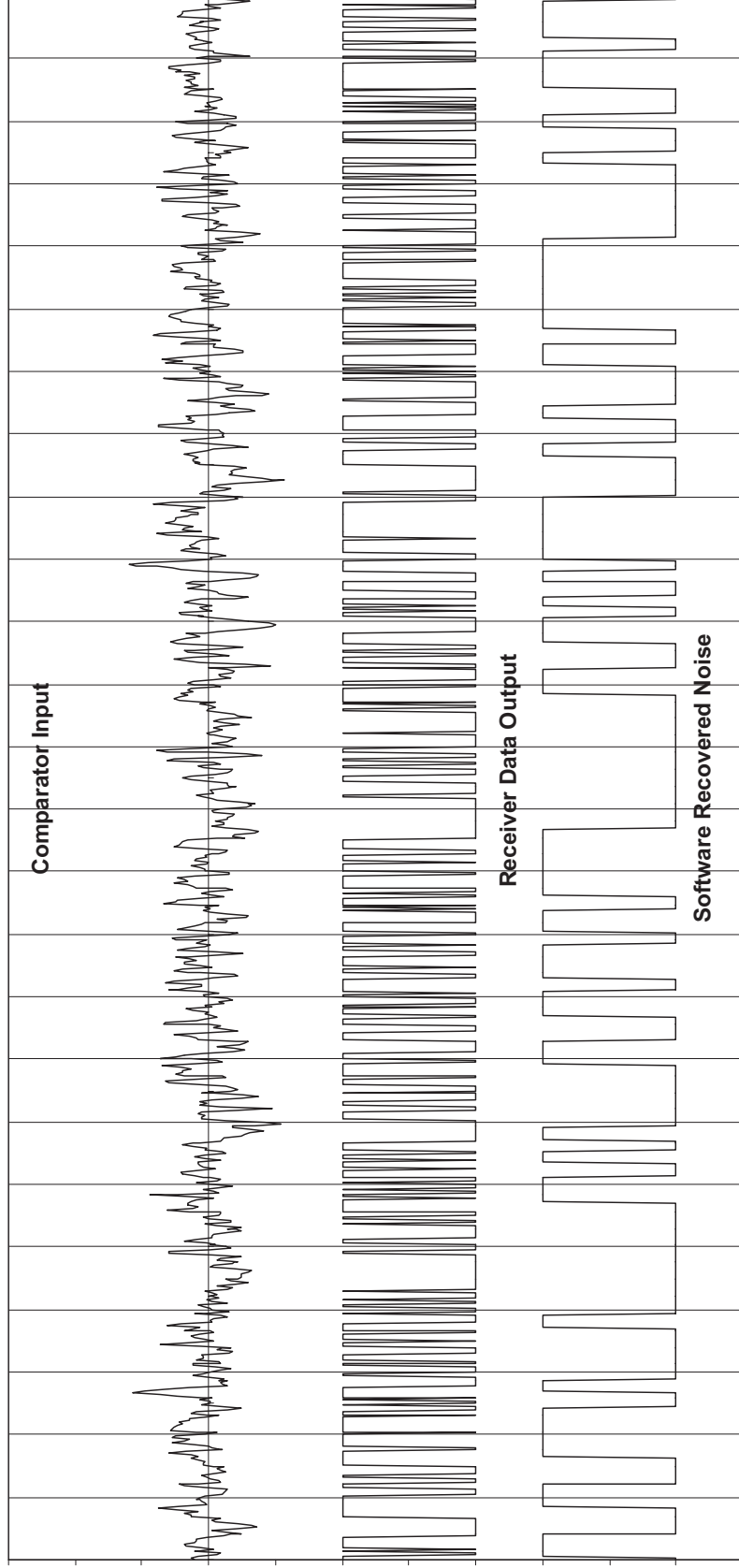

Figure 2.2.1

Noise Reception with No Signal and Moderate Threshold

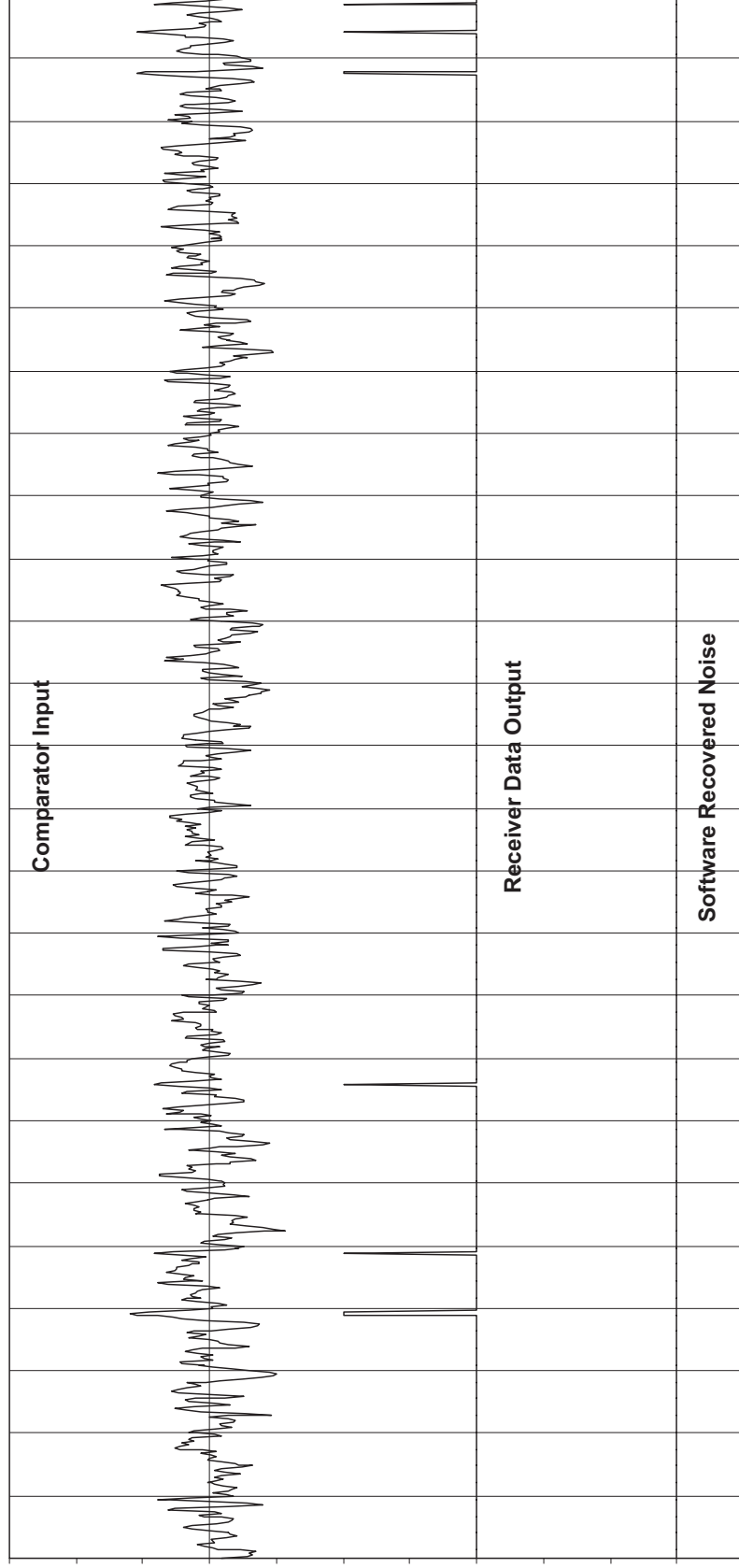

Figure 2.2.2

comparator. The preamble is followed by a specific pattern of bits that will not occur anywhere else in the message. This pattern is often called a “sync vector”, and makes it possible to distinguish data from noise with high reliability (the sync vector is 12 bits in this example). The balance of the message consists of encoded data and error detection bits.

The purpose of encoding your data is to maintain good slicing symmetry at the input to the comparator. This is called DC-balanced encoding. Look at Figure 1.2.3.2 again. There are five bit periods between each vertical grid line. Notice that you will not find more than three 1 or 0 bits in a row in the data shown, and that there are always six ones and six zeros in any sequence of 12 bits. This is because each message byte has been encoded as 12 bits, always with six ones and six zeros, and with no more than four bits of the same type in a row for any combination of adjacent encoded characters. This is one type of coding that maintains good dynamic DC balance, and is similar to techniques used in fiber-optic data transmissions. Another popular encoding scheme is Manchester encoding, which encodes each 1 bit in the message as a 1-0 bit sequence, and each 0 bit in the message as a 0-1 bit sequence. Both 12-bit encoding and Manchester encoding work well. Manchester encoding has a maximum of two bits of the same type in a row, but requires 16 bits to encode a byte. 12-bit encoding can have up to 4 bits of the same type in a row, and requires, of course, 12 bits to encode a byte. By the way, your start vector should also be dynamically DC balanced in most cases.

The data rate and the encoding scheme you use affects two adjustments on the ASH transceiver (or vice versa). The most narrow pulse or gap in your encoded data sets the low-pass filter bandwidth. For the two encoding schemes we have discussed, this is one encoded bit period. Once you know the bit period, Section 2.5 in the ASH Transceiver Designer’s Guide explains how to set the low-pass filter bandwidth. The widest pulse or gap in your encoded data sets the value of the coupling capacitor. Once you know the maximum number of 1 bits or 0 bits that can occur in a row, you know the width of the maximum pulse or gap that can occur in your encoded data. Section 2.6 in the ASH Transceiver Designer’s Guide explains how to determine the coupling capacitor value and the required training preamble length from the maximum pulse or gap width.

Trying to send data without encoding is generally a disaster. Without a threshold, any long sequence of 1’s or 0’s in your data will charge or discharge the coupling capacitor, unbalancing the symmetry of the signal into the data slicer and ruining the noise rejection performance.

When you use one of the data encoding schemes discussed above with no slicer threshold, the coupling-capacitor transient response automatically adjusts the slicing symmetry as variations occur in received signal strength. This greatly improves system robustness to signal flutter. You usually want to make the coupling-capacitor value no larger than needed, so that fast signal fluctuations can be followed.

Let’s now consider message encoding schemes and ASH transceiver adjustments when a threshold is used. Again, a threshold trades-off sensitivity and flutter robustness for less noise in the no-signal condition. If you are using a strong threshold, you may decide you

do not need a training preamble or start vector (this depends on the way you design your code). But if you are using AGC and/or data slicer DS2 in your ASH transceiver, you will need at least one 1-0-1-0... preamble byte for training these hardware functions. The threshold in DS1 has a built-in hysteresis. When the input voltage to the data slicer exceeds the threshold level, DS1 will output a logic 1, and it will continue to output a logic 1 until the input voltage swings below zero. The DC-balanced data encoding methods already discussed work satisfactorily with the DS1 hysteresis. Again, once you know the bit period of your encoded data, Section 2.5 in the ASH Transceiver Designer's Guide explains how to set the low-pass filter bandwidth. Note that a larger bandwidth is recommended for the same bit period when a threshold is used. Using the coupling capacitor value as determined in Section 2.6 of the ASH Transceiver Designer's Guide is a good default choice. When you use a threshold, 1 bits tend to drop out of weak and/or fluttering signals at the data slicer. Message patterns that contain a few less 1 bits than 0 bits work somewhat better with a strong threshold than classical DC-balanced codes. In some cases you may work with encoder and decoder chips designed to send command codes. Some of these chips send code messages with short preambles and relatively large gaps between the messages. These chips often work better if you use a moderate threshold and a relatively large coupling capacitor, so it is worth doing some experimenting.

2.3 Clock and Data Recovery

The clock and data recovery techniques used at the receiver are critical to overall system performance. Even at moderate signal-to-noise ratios, the output of the data slicer will exhibit some jitter in the position of the logic transitions. At lower signal-to-noise ratios, the jitter will become more severe and spikes of noise will start to appear at the data slicer output, as shown in Figure 1.2.3.5. The better your clock and data recovery techniques can handle edge jitter and occasional noise spikes, the more robust your radio link will be. There is some good news about edge jitter due to Gaussian noise. The average position of the logic transitions are in the same place as the noise-free case. This allows you to use a phase-locked loop (PLL) that hones in on the average position of the data edges for clock recovery. Once your clock recovery PLL is lined up, you can use the logic state at the middle of each bit period, or the dominant logic state across each bit period as your recovered bit value. Testing mid-bit works best when the low-pass filter is well-matched to the data rate. On the other hand, determining the dominant logic state across a bit period can improve performance when the low-pass filter is not so well matched. The dominant logic state is often determined using an "integrate and dump" algorithm, which is a type of averaging filter itself.

It is possible to use simple data recovery techniques for less demanding applications (close operating range so the signal-to-noise ratio is high). The standard protocol software that comes in the DR1200-DK, DR1201-DK and DR1300-DK Virtual Wire® Development Kits uses a simplified data recovery technique to achieve air transmission rates of 22.5 kbps with a modest microcontroller. And yes, ordinary UARTs are being used successfully in non-demanding applications. But a word of caution. It appears the UARTs built into some microcontroller chips really don't like even moderate edge jitter. If you

are considering using a built-in UART on the radio side, do some testing before you commit your design to that direction.

About now you may be wondering if anybody builds an “RF UART”, which is designed for low signal-to-noise ratio applications. The IC1000 discussed below is one example of this concept.

2.4 Communication Protocols

So far, we have discussed message encoding techniques for robust RF data transmission, and clock and data recovery techniques that can work with some noise-induced edge jitter and occasional noise spikes. Even so, transmission errors and drop outs will occur. The main job of your communication protocol is to achieve near-perfect communications over an imperfect RF communication channel, or to alarm you when a communication problem occurs. And channel sharing is often another requirement.

A protocol is a set of standard structures and procedures for communicating digital information. A complete protocol is often visualized as a stack of structures and procedures that are very specific to the communication hardware and channel characteristics at the bottom, and more general-purpose and/or application oriented at the top.

Packet-based protocols are widely used for digital RF communications (and for sending data on many other types of communications channels.) Even simple command transmissions usually employ a packet-style data structure.

2.4.1 Digital command transmissions

In addition to ASH transceivers, RFM’s second-generation ASH radio product line includes transmitter and receiver derivatives for one-way RF communications. Most one-way command applications are actually two-way; RF in one direction and audible or visual in the other direction. For example, you press the “open” button until you see the garage door or gate start moving. The data encoding and data recovery techniques discussed above can be used to build a robust one-way RF communications system. But often, off-the-shelf command encoder and decoder ICs are used. Among the most popular are the Microchip KeeLoq™ ICs. Figure 2.4.1 shows RFM’s suggested application circuit for second-generation ASH receivers driving KeeLoq™ decoders. You can usually derive enough information from the data sheets of other encoder and decoder ICs to calculate the component values to use with second-generation ASH receivers. The calculations are the same as discussed in the ASH Transceiver Designer’s Guide.

There is a growing trend to replace one-way RF communication links with two-way links for added system integrity. This is especially true for one-way RF communication links that are not activated by the user. Wireless home security systems are one example.

ASH Receiver Application Circuit KeeLoq Configuration

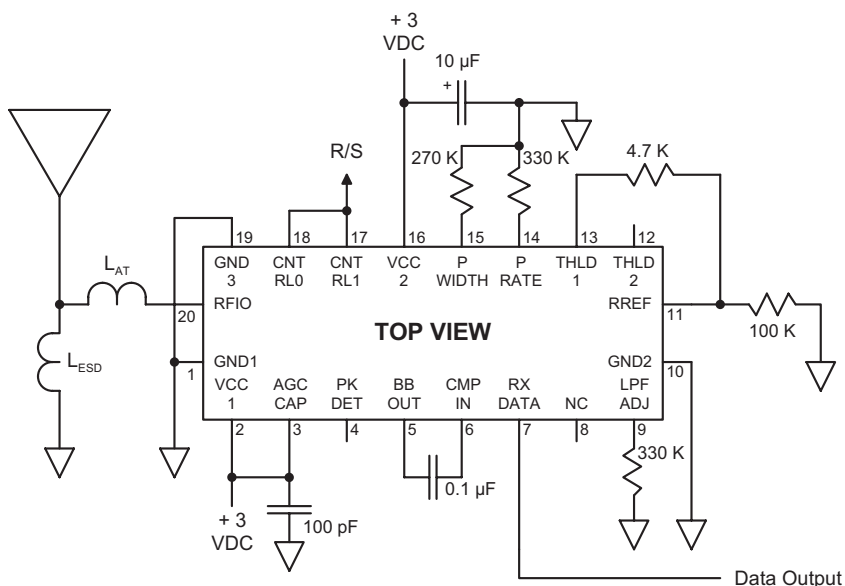

Figure 2.4.1

2.4.2 Data transmissions using packet protocols

A packet structure generally includes a training preamble, start symbol, routing information (to/from, etc.) packet ID, all or part of a message, and error detection bits. Other information may be included depending on the protocol. Communications between nodes in a packet-based system may be uncoordinated (talk when you want to) or coordinated (talk only when it is your turn). In the case of uncoordinated transmissions, packet collisions are possible. Theorists note that the collision problem limits the throughput of an uncoordinated channel to about 18% of its steady one-way capacity. Coordinated transmissions have higher potential throughput but are more complex to code. Many applications that use ASH radio technology transmit relatively infrequently, so uncoordinated transmissions work very successfully.

In both uncoordinated and coordinated systems, transmission errors can and will occur. An acknowledgment (ACK) transmission back to the sending node is used to confirm that the destination node has received the packet error free. Error-detection bits are added to a packet so the destination node can determine if the packet was received accurately. Simple parity checks or checksums are not considered strong enough for error checking RF transmissions. The error-detection bits added to the end of a packet are often called a frame check sequence (FCS). An FCS is usually 16 to 24 bits long, and is generated using a cyclic redundancy code (CRC) method. IBM developed such a code many years ago for their X.25 protocol and it is still widely used for RF packet transmissions. The ISO3309

Standard details the generation of this error detection code, and it is used in the protocol code example below.

It is time to bring up the real challenge in designing and writing protocol software. Events can happen in any sequence, and data coming into the protocol software can be corrupted in any bit or in every bit (remember, short packets work best on a low signal-to-noise radio channel). It is worth doing a careful “what if” study relevant to your protocol and your application before doing the detailed design and coding of your software. Consider how you can force unlikely sequences of events in your testing. Thorough front end planning can avoid a lot of downstream problems.

3 IC1000 “Radio UART”

RFM has introduced the IC1000 to support fast-track product development cycles using ASH radio technology. The IC1000 implements the clock and data recovery tasks that often constitute a lot of the learning curve in your first RF protocol project. The IC1000 is designed to operate with no threshold, which is the key to good system sensitivity.

3.1 IC1000 Description

The IC1000 is implemented in an industrial temperature range PIC12LC508A-04I\SN microcontroller using internal clocking. Nominal operating current is 450 μ A, consistent with the low operating current emphasis of the second-generation ASH radio product line. The IC1000 is provided in a miniature eight-pin SMT package.

3.2 IC1000 Application

A typical IC1000 application is shown in Figure 3.2.1. The data (slicer) output from the second-generation ASH transceiver is buffered by an inverting buffer and is applied to Pin 3 of the IC1000 and the Data In pin of the host microprocessor. When the IC1000 detects the presence of a specific start-of-data pulse sequence, it outputs a Start Detect pulse on Pin 2. This pulse is applied to an interrupt pin on the host processor. The IC1000 generates data clocking (data valid) pulses in the middle of each following bit period using an oversampled clock extraction method. The IC1000 is designed to tolerate continuous input noise while searching for a start-of-data pulse sequence.

The IC1000 supports four data rates - 2400, 4800, 9600, and 19200 bits per second (bps). The data rate is selected by setting the logic input levels to Pin 6 (Speed 1) and Pin 7 (Speed 0). Please refer to the IC1000 data sheet for additional information.

4 Example Data Link Layer Protocol

The data link protocol discussed below is tuned for high-sensitivity, low data rate requirements. The protocol code is designed to run on the ATMEL AT89C2051 microcontroller used in the DR1200-DK/DR1200A-DK Series Virtual Wire® Development Kits. The “A” version kits (DR1200A-DK, etc.) ship with this software and require no hardware

received packets. This can be handy for driving small serial printers, etc. You do not use jumpers to set the FROM address with this protocol.

Details of the packet and byte structures used by the protocol are shown in Figure 4.4. The host-protocol packet structure begins and ends with a 0C0H framing character (FEND) that cannot be used elsewhere in the packet. For example, you cannot use 0C0H in the TO/FROM address byte. This will otherwise not be a problem using seven-bit ASCII message characters. Eight-bit data can be sent using seven-bit ASCII characters to represent numerical values, or a framing character substitution scheme like the one used in the Internet SLIP protocol can be employed. The framing character helps deal with the “non real time” nature of serial ports on your typical PC. The host-protocol packet structure within the frame includes the TO/FROM address byte, with the high nibble the TO address and the low nibble the FROM address. The ID byte indicates which packet this is. Each packet can hold up to 24 additional message bytes. As mentioned, short packets should be used on radio channels.

Framing characters are not needed in the transmitted packet structure as the protocol is real time on the radio side. The transmitted packet structure begins with a 1-0-1-0... preamble which establishes good signal slicing symmetry at the input to the radio comparator and then trains the clock and data recovery processes in the software. The preamble is followed by a 12-bit start symbol that provides good discrimination to random noise patterns. The number of bytes in the packet (beyond the start symbol), the TO/FROM address, packet ID, message bytes and FCS then follow. The start symbol and all bytes following are 12-bit encoded for good dynamic DC balance.

Packet and Byte Structure Details

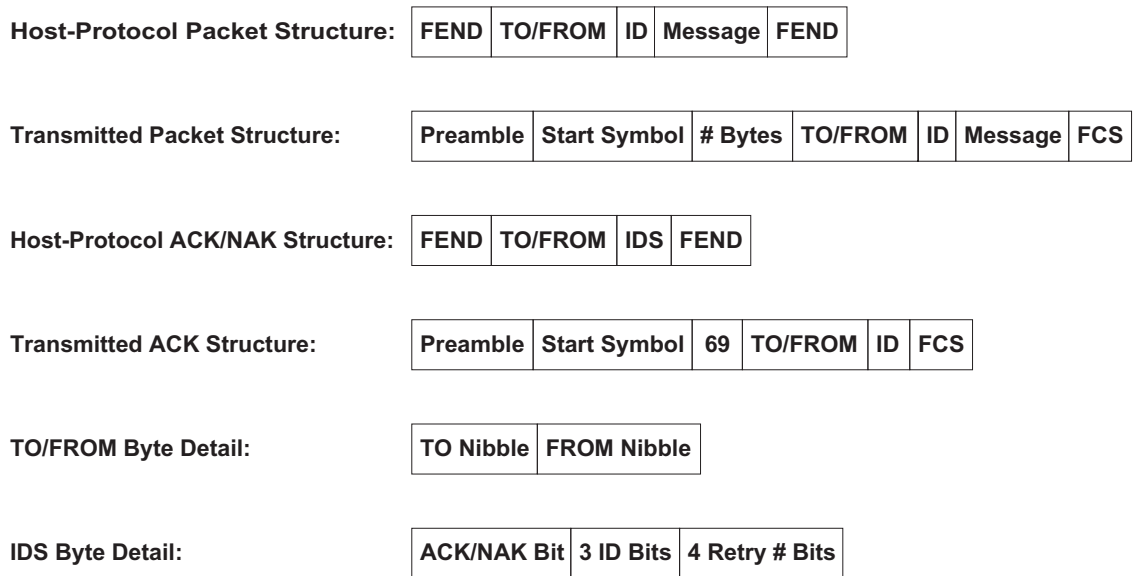

Figure 4.4

ACK and NAK packets contain an IDS byte which is detailed in Figure 4.4. The most significant bit in this byte is set to 1 for an ACK or 0 for a NAK. The next three bits are the packet ID, and the lower nibble of the byte holds the retry number for the ACK.

On power up the program is initialized by a call to the `setup` subroutine. The program then begins running in the `main` loop. The `tick` subroutine is called every 104.18 microseconds through `t_isr`, the interrupt service routine for timer T0. The `tick` subroutine always runs, and provides support for data reception, data transmission and event timing. The `tick` subroutine has a number of operating modes, controlled by the state of several flags.

Most of the time, `tick` will call `pll`, the receiver clock and data recovery subroutine. The `pll` subroutine uses two simple but effective signal processing techniques for accurately recovering bits from a data input stream with edge jitter and occasional noise spikes. The first signal processing technique is PLL clock alignment and the second technique is integrate-and-dump (I&D) bit estimation.

Register R2 acts as a modulo 0 to 159 ramp counter that wraps on overflow about every 8 sampling ticks, (one bit period). This provides an 500 microsecond bit period, which equates to a nominal RF data rate of 2000 bits per second. Unless an edge occurs in the incoming bit stream, the ramp is incremented by 12.5% on each tick. If an edge occurs (change of logic state between ticks), the ramp is incremented 6.875% if the ramp value is below 80, or is incremented 18.125% if the ramp value is equal to or greater than 80. This causes the ramp period to gradually slide either backward or forward into alignment with the average bit period of the incoming data. After alignment, the position of the ramp can only change $\pm 5.625\%$ on each incoming data edge. Moderate edge jitter and occasional noise spikes will not seriously affect the ramp's alignment with the incoming data. Note that a preamble is needed to train the PLL (slide it into alignment).

Once the ramp is aligned, the I&D bit estimate becomes meaningful. The count in buffer `RXID` is incremented on each tick within a bit period if input sample `RXSMP` is a logic 1. At the end of the bit period (R2 overflow wrap), the incoming bit is estimated to be a 0 if the count is four or less, or a 1 if the count is five or more. `RXID` is then cleared (dumped) in preparation for the next bit estimate. Integrate-and-dump estimation provides additional noise filtering by effectively averaging the value of the input samples within a bit period.

Once a bit value is determined, subroutine `pll` either inputs it into a 12-bit buffer (lower nibble of `RXBH` plus `RXBL`) used to detect the message start symbol, or adds it to buffer `RXBB`, which collects six-bit half symbols from the incoming encoded message. Flag `SOPFLG` controls which of these actions are taken.

You will notice that `tick` samples the RX input pin near the start of the subroutine, and when transmitting, outputs a TX bit sample as one of the first tasks. This helps minimize changes in the delay between timer T0 activating `t_isr` and these input/output events. If these activities are placed further down in the `tick` code or in the `pll` subroutine, an

effect similar to adding extra noise-induced jitter can occur as different branches are taken through the code.

In addition to supporting data reception and transmission, the `tick` subroutine runs several timer functions. One timer provides a time-out for partial messages arriving from the host. The `AutoSend` timer and the transmit retry timer are also part of the `tick` subroutine.

The other interrupt service routine used by the protocol software is `sisr`, which supports serial port interrupts by calling `srio`. The function of `srio` is to provide priority reception of messages from the host. An acknowledgment back to the host confirms the serial interrupt was enabled and the protocol received the host's message.

As mentioned, the code starts running in the `main` loop. A number of subroutines can be called from this loop, depending on the state of their associated control flags. Here are these subroutines and what they do:

The `do_as` subroutine automatically transmits a "Hello" test message paced by a timer in `tick`. This `AutoSend` function is activated by a call from `setup` if a jumper is detected across the pins near the "dot" end on the protocol board, as discussed above.

The `do_rt` subroutine retransmits a message if an ACK has not been received. Retransmissions are paced by a timer in `tick`. The timer is randomly loaded with one of eight different delays, which helps reduce the possibility of repeated collisions between two nodes trying to transmit a message at the same time. The protocol will attempt to transmit a message up to eight times. The `do_rt` subroutine manages attempts two through eight as needed.

The `ak_snd` subroutine sends an ACK/NAK message back to the protocol's host to indicate the outcome of attempting to transmit a message. When called directly from the `main` subroutine, it sends a NAK message. When called from `do_rx`, it sends an ACK.

The `rx_sop` subroutine detects the message start symbol (SOP) by comparing the bit pattern in the 12-bit correlation buffer updated by `pll` to the start symbol pattern. When the SOP pattern is detected, `rx_sop` modifies flag states and clears buffers in preparation for receiving the encoded message. As mentioned, this protocol uses 12-bit encoding to achieve dynamic DC balance. The start symbol is not one of the 12-bit symbols used in the encoding table, but it is also DC balanced.

The `do_rx` subroutine receives and decodes the incoming message, tests the FCS for message accuracy, returns an ACK to the sender if it has received an error-free data message for this node, sends an ACK message to the host if it has received an ACK message for this node, and sends an error-free data message to the host if the message is for this node. These tasks are done by calling subroutines from `do_rx`. Here are these subroutines and what they do:

The `rxmsg` subroutine receives each six-bit half symbol from `pll` and converts it to a decoded nibble using the `smb l` table near the end of the listing. Decoded nibbles are assembled into bytes and added to the received message buffer. When all the message is received, control is returned to `do_rx`. If a message length overflow occurs, `rxmsg` fakes a short message that will fail the FCS test.

The `rx fcs` subroutine tests the message for errors by recalculating the FCS with the transmitted FCS bits included in the calculation. If there are no errors, the received FCS calculation will equal 0F0B8H. The `rx fcs` subroutine uses calls to `b_r fcs` and `a_r fcs` to do the FCS calculation and to test the results.

The `ack tx` subroutine determines if the received message is an ACK for a packet (ID) being transmitted from this node. If so, `ack tx` idles transmission attempts and signals `rxmsg` to send an ACK message to the host by setting flag states.

When called from `rxmsg`, `aksnd` sends an ACK message to the host. Notice that when `aksnd` is called from `main`, it sends a NAK message.

The `ack rx` subroutine transmits an ACK message back to the sending node when it receives a valid data message from the sending node addressed to it. The subroutines used by `ack rx` are “borrowed” from the transmit side of the protocol and will be discussed later.

The `rxsnd` subroutine sends a received data message to the host, provided the message is for its node and has passed the FCS test.

The `rxrst` subroutine resets flags and initializes buffers in preparation for receiving the next packet.

The first byte of a packet sent from the host triggers the serial interrupt service routine `t_isr` which calls subroutine `srio`. The serial interrupt is disabled and the `do_tx` subroutine is called. This subroutine takes in the message from the host, computes the FCS, turns the transmitter on, sends the preamble and start symbol, encodes and sends the message, and turns the transmitter off. The `do_tx` subroutine accomplishes these actions by calling other subroutines. Here are these transmit subroutines and what they do:

The `txget` subroutine receives the message from the host and loads it into the transmit message buffer. Provisions are made in `txget` to exit on a null message (just two FENDs), time-out on partial messages, or send the first part of an incoming message that is overflowing in length. Since the serial interrupt service routine is disabled from time-to-time, a short packet transfer acknowledgment message (PAC) is sent back to the host to confirm the protocol has the message and is attempting to transmit it. No PAC is sent on a null message or a time-out as there is nothing to send.

The `txfcs` subroutine calculates the FCS that will be used for error detection at the receive end. It uses calls to `b_tfc s` and `a_tfc s` to do the FCS calculation and to add the results to the message.

The `txpre` subroutine turns on the transmitter and after a short delay sends the preamble and start symbol using the data in the `tsrt` table near the end of the listing. Note that `txpre` is supported by `tick` to provide sample-by-sample bit transmission.

The `txmsg` subroutine encodes the message bytes as 12-bit symbols and transmits them in cooperation with `tick`. This subroutine uses the `smb l` table to encode each nibble in each message byte into six bits.

The `txrst` subroutine can either reset to send the same message again or can reset to receive a new message from the host, based on flag states.

The `do_tx` subroutine receives a message from the host and attempts to transmit it once. Additional transmit attempts are done by `do_rt`, which is called from `main` as needed. The `do_rt` subroutine uses most of the same subroutines as `do_tx`. The `do_as` subroutine can also be called from `main` to provide the AutoSend test transmission and it also uses many of the same subroutines as `do_tx`. And as mentioned earlier, `ackrx` uses several of these subroutines to transmit an ACK back for a received message.

4.2 Terminal Program Source

V110T30C.FRM is the Visual Basic source code for the companion terminal program to DK200A.ASM. After initializing flags, variables, etc., the form window is shown and the program starts making periodic calls to the `Timer1_Timer` “heartbeat” subroutine. The `Xfer` subroutine provides time-outs for PAC, ACK or NAK messages expected back from the protocol. `Xfer` is also handy for reminding you to turn on the power switch or put fresh batteries in the protocol board. The PC’s serial input buffer is set up for polling (no interrupts) and is serviced by calling `RxPtk` from `Timer1_Timer`. The terminal program also has an AutoSend subroutine, `ASPkt`, that is called from `Timer1_Timer` when AutoSend is active. (No, you are not supposed to use the AutoSend feature in the protocol and the host program at the same time.) Here is a listing of the terminal program subroutines and what they do:

`RxPkt` is called from `Timer1_Timer` when bytes are found in the serial port input buffer. `RxPkt` calls two other subroutines, `InCom` and `ShowPkt`.

`InCom` collects bytes from the serial port input buffer for a period of time set by the `InDel!` variable. These bytes are added to the end of the `Rpkt$` string variable, which acts as byte FIFO.

`ShowPkt` is then called to display or otherwise process the bytes in `RPkt$`. The outer `Do, Loop Until (J = 0)` structure takes advantage of the framing characters to separate individual packets in `RPkt$`. This avoids the need for reading the PC's serial port input buffer at precise times which you probably can't do anyway. As each packet is removed from the left side of `RPkt$`, it is checked to see if it is a one-character PAC (OFFH character), a two-character ACK or NAK, or a data message of three or more characters. Flags `TFlag`, `ANFlag`, `NAFlag` and `TNFlag` are reset by `ShowPkt` as appropriate and are used by the `Xfer` monitoring subroutine to confirm messages are flowing back from the protocol in a timely manner. The `NAFlag` enables the next `AutoSend` transmission. The `ShwACK` flag selects either to display inbound messages (and `PID Skips`) only, or inbound messages plus PAC, ACK/NAK, TO/FROM and ID information.

`Text1_KeyPress` is used to build messages for transmission. Editing is limited to backspacing, and the message is sent by pressing the Enter key or entering the 240th character.

`SndPkt` breaks the message into packets, adds the framing characters, the TO/FROM address and the ID number to each packet and sends them out. `SndPkt` sets the `TFlag` and `ANFlag` flags and clears the value of several variables. `NxtPkt` is a small subroutine used by `SndPkt` that picks a new ID number for each packet.

`Xfer` monitors the elapsed time from when a packet is sent out (to the protocol) and a PAC is received back, and the elapsed time from when a packet is sent out and an ACK or NAK is received back. `Xfer` will display error messages and reset control flags and other variables through `ResetTX` if these elapsed times get too long.

`ASPkt` automatically sends test packets using the `NxtPkt` and `SndPkt` subroutines. It is paced by the state of the `NAFlag`.

`GetPkt` is a small subroutine that supplies `ASPkt` with a message. Until the first message is typed in, `GetPkt` provides a default message. It otherwise provides the last message typed in.

`LenTrap` clears a text window when 32,000 bytes of text have accumulated in it.

The remaining subroutines in the terminal program are classical event procedures related to mouse clicks on the terminal program window. Most of these relate to the Menu bar.

The three top level choices on the Menu bar are *File*, *Edit* and *View*. Under *File* you can choose to *Exit* the terminal program. Under *Edit*, the next level of choices are the *To Address* and the *From Address*. Under the *To Address* you can choose *Nodes 1, 2, 3, or 4*, with *Node 2* the default. Under the *From Address* you can choose *Nodes 1, 2, 3, or 4*, again with *Node 2* the default.

Under *View* you can choose *Clear* (screen), *Show RX Dups*, *Show ACK/NAK*, and *AutoSend*, as discussed earlier. The status bar and its embedded progress bar at the bottom of the form monitors outbound packets even when *Show ACK/NAK* is not enabled.

4.3 Variations and Options

In most real world applications, `s_isr`, `s_rto`, `txget`, `rxsnd` and `aksnd` would be replaced with resident application subroutines. Your real-world application is left as a homework assignment. Test, test, test!

Another pair of programs are provided for your experimentation. `DK110K.ASM` is a simplified “shell” protocol that transmits a message received from the host (once) and sends any message received with a valid FCS to the host. PAC/ACK/NAK handshaking between the host and the protocol and between protocol nodes is not implemented. Also, no TO/FROM address filtering is provided at the protocol level. This gives you the flexibility to add these types of features either to the protocol or the terminal program yourself. Terminal Program `V110T05B.FRM` works with `DK110K.ASM` and provides a simple implementation of ACK/NAK handshaking at the host level. Of course, `DK110K.ASM` is not intended to work with `V110T30C.FRM` and `DK200A.ASM` is not intended to work with `V110T05B.FRM`.

4.4 Test Results

Laboratory tests show that a 916.5 MHz ASH radio system using the example software achieves a bit-error-rate between 10^{-4} and 10^{-3} at a received signal level of -101 dBm using pulse modulation (or -107 dBm using 100% amplitude modulation). Open-field range tests using commercial half-wave dipole antennas (Astron Antenna Model AXH9NSMS) demonstrate good performance chest-high at distances of one-eighth mile or more.

5 Source Code Listings

5.1 DK200A.ASM

```
; DK200A.ASM 2002.07.31 @ 20:00 CST
; See RFM Virtual Wire(r) Development Kit Warranty & License for terms of use
; Experimental software - NO representation is
; made that this software is suitable for any purpose
; Copyright(c) 2000 - 2002, RF Monolithics, Inc.
; AT89C2051 assembler source code file (TASM 3.01 assembler)
; Low signal-to-noise protocol for RFM ASH transceiver
; Integrate & dump PLL (I&D) - 62.40 us tick

        .NOLIST
        #INCLUDE "8051.H"          ; tasm 8051 include file
        .LIST

; constants:

ITMOD   .EQU    022H              ; set timers 0 and 1 to mode 2
ITICK   .EQU    141              ; set timer T0 for 62.40 us tick
ISMOD   .EQU    080H              ; SMOD = 1 in PCON
IBAUD   .EQU    0FAH              ; 19.2 kbps @ 22.1184 MHz, SMOD = 1
ISCON   .EQU    050H              ; UART mode 1

RMPT    .EQU    159              ; PLL ramp top value (modulo 0 to 159)
RMPW    .EQU    159              ; PLL ramp reset (wrap) value
RMP5    .EQU    80                ; PLL ramp switch value
RMPI    .EQU    20                ; PLL ramp increment value
RMPA    .EQU    29                ; PLL 5.625% advance increment value (20 + 9)
RM5R    .EQU    11                ; PLL 5.625% retard increment value (20 - 9)

AKMB    .EQU    03EH              ; ACK message buffer start address
TXMB    .EQU    043H              ; TX message buffer start address
TFTX    .EQU    044H              ; TO/FROM TX message buffer address
IDTX    .EQU    045H              ; packet ID TX message buffer address
RXMB    .EQU    061H              ; RX message buffer start address
TFRX    .EQU    062H              ; TO/FROM RX message buffer address
IDRX    .EQU    063H              ; packet ID RX message buffer address
FEND    .EQU    0C0H              ; FEND framing character (192)
SOPH    .EQU    08AH              ; SOP low correlator pattern
SOPH    .EQU    0B3H              ; SOP high correlator pattern
TXR0    .EQU    026H              ; TX retry timer count

FCSS    .EQU    0FFH              ; FCS seed
FCSH    .EQU    084H              ; FCS high XOR mask
FCSL    .EQU    08H               ; FCS low XOR mask
FCVH    .EQU    0F0H              ; FCS valid high byte pattern
FCVL    .EQU    0B8H              ; FCS valid low byte pattern

; stack: 08H - 021H (26 bytes)

; bit labels:

WBFLG   .EQU    010H              ; warm boot flag (future use)
PLLON   .EQU    011H              ; RX PLL control flag
RXISM   .EQU    012H              ; RX inverted input sample
RXSMP   .EQU    013H              ; RX input sample
LRXSM   .EQU    014H              ; last RX input sample
RXBIT   .EQU    015H              ; RX input bit
RXBFLG  .EQU    016H              ; RX input bit flag
SOPFLG  .EQU    017H              ; SOP detect flag
RXSFLG  .EQU    018H              ; RX symbol flag
RM       .EQU    019H              ; RX FCS message bit
OKFLG   .EQU    01AH              ; RX FCS OK flag

SIFLG   .EQU    01BH              ; serial in active flag
TSFLG   .EQU    01CH              ; output TX sample flag
TXBIT   .EQU    01DH              ; TX message bit
TM       .EQU    01EH              ; TX FCS message bit
TXFLG   .EQU    01FH              ; TX active flag
TMFLG   .EQU    020H              ; TX message flag
TOFLG   .EQU    021H              ; get message time out flag

AMFLG   .EQU    022H              ; AutoSend message flag
ASFLG   .EQU    023H              ; AutoSend active flag
ANFLG   .EQU    024H              ; ACK/NAK status flag
```

```

SAFLG      .EQU      025H      ; send ACK/NAK flag
NHFLG      .EQU      026H      ; no RX FEND/header flag

SFLG1      .EQU      027H      ; spare flag 1
SFLG2      .EQU      028H      ; spare flag 2
SFLG3      .EQU      029H      ; spare flag 3
SFLG4      .EQU      02AH      ; spare flag 4
SFLG5      .EQU      02BH      ; spare flag 5
SFLG6      .EQU      02CH      ; spare flag 6
SFLG7      .EQU      02DH      ; spare flag 7
SFLG8      .EQU      02EH      ; spare flag 8
SFLG9      .EQU      02FH      ; spare flag 9

; register usage:

; R0              RX data pointer
; R1              TX data pointer
; R2              PLL ramp buffer
; R3              RX FCS buffer A
; R4              not used
; R5              TX FCS buffer A
; R6              TX FCS buffer B
; R7              RX FCS buffer B

; byte labels:

BOOT       .EQU      022H      ; 1st byte of flags

RXID       .EQU      026H      ; RX integrate & dump buffer
RXBL       .EQU      027H      ; RX low buffer, SOP correlator, etc.
RXBH       .EQU      028H      ; RX high buffer, SOP correlator, etc.
RXBB       .EQU      029H      ; RX symbol decode byte buffer
RMDC       .EQU      02AH      ; RX symbol decode loop counter
RMBIC      .EQU      02BH      ; RX symbol decode index pointer
RMBYC      .EQU      02CH      ; RX message byte counter
RMFCS      .EQU      02DH      ; RX FCS byte buffer
RMSBC      .EQU      02EH      ; RX symbol bit counter
RMLPC      .EQU      02FH      ; RX message loop counter
RMFCC      .EQU      030H      ; RX message FCS counter, etc.

TMFCC      .EQU      031H      ; TX timer & loop counter
TXSMC      .EQU      032H      ; TX output sample counter
TMBIC      .EQU      033H      ; TX message bit counter
TMBYT      .EQU      034H      ; TX message byte buffer
TMBYC      .EQU      035H      ; TX message byte counter
TXSL       .EQU      036H      ; TX message symbol low buffer
TXSH       .EQU      037H      ; TX message symbol high buffer
TMFCS      .EQU      038H      ; TX FCS byte buffer
TXTL       .EQU      039H      ; TX timer low byte
TXTH       .EQU      03AH      ; TX timer high byte
TXCNT      .EQU      03BH      ; TX retry counter
IDBUF      .EQU      03CH      ; packet ID buffer
TFBUF      .EQU      03DH      ; TO/FROM address buffer

; I/O pins:

MAX        .EQU      P1.6      ; Maxim 218 power (on = 1)

RXPIN      .EQU      P3.2      ; RX input pin (inverted data)
TXPIN      .EQU      P3.3      ; TX output pin (on = 1)
PTT        .EQU      P1.7      ; transmit enable (TX = 0)

PCRCV      .EQU      P3.7      ; PC (host) input LED (on = 0)
RFRVCV     .EQU      P3.5      ; RX FCS OK LED (on = 0)
RXI        .EQU      P3.4      ; RX activity LED (on = 0)

ID0        .EQU      P1.2      ; jumper input bit 0 (dot end)
ID1        .EQU      P1.3      ; jumper input bit 1
ID2        .EQU      P1.4      ; jumper input bit 2
ID3        .EQU      P1.5      ; jumper input bit 3

; start of code:

          .ORG      00H      ; hardware reset
SETB       WBFLG          ; set warm boot flag
reset:    AJMP      start    ; jump to start

          .ORG      0BH      ; timer 0 interrupt vector
t_isr:    ACALL     tick     ; sampling tick subroutine
          RETI          ; interrupt done

```

```

s_isr:   .ORG      023H      ; serial interrupt vector
        ACALL    srio      ; serial I/O subroutine
        CLR     TI        ; clear TI (byte sent) flag
        CLR     RI        ; clear RI (byte received) flag
        RETI     ; interrupt done

start:   .ORG      040H      ; above interrupt code space
        ACALL    setup     ; initialization code

main:    JNB     AMFLG,mn0   ; skip if AutoSend idle
        CLR     PCRCV     ; else turn PCRCV LED on
        ACALL    do_as     ; do AutoSend
        SETB    PCRCV     ; turn PCRCV LED off
        AJMP    mn1       ; and jump to RX SOP detect
mn0:     JNB     TMFLG,mn1   ; skip if TX message idle
        CLR     PCRCV     ; else turn PCRCV LED on
        ACALL    do_rt     ; do TX retry
        SETB    PCRCV     ; turn PCRCV LED off
mn1:     JNB     SAFLG,mn2   ; skip if send ACK/NAK flag reset
        ACALL    aksnd     ; else send NAK to host
mn2:     ACALL    rx sop    ; do RX SOP detect
        JNB     SOPFLG,main ; if not SOP loop to main
        ACALL    do_rx     ; else do RX message
mn_d:    AJMP    main      ; and loop to main

do_rx:   CLR     ES        ; deactivate serial interrupts
        ACALL    rxmsg     ; decode RX message
        CLR     PLLON     ; idle RX PLL
        ACALL    rxfcs     ; test RX message FCS
        JNB     OKFLG,rx2  ; reset if FCS error
        JNB     TXFLG,rx0  ; skip if send TX idle
        ACALL    acktx     ; if TX ACK, set send ACK flag
        JNB     SAFLG,rx0  ; skip if send ACK/NAK flag reset
        ACALL    aksnd     ; else send ACK message to host
        AJMP    rx2       ; and jump to reset RX
rx0:     JB      ASFLG,rx1  ; don't ACK AutoSend
        ACALL    ackrx     ; ACK RX message
rx1:     ACALL    rxsnd     ; send RX message to host
rx2:     ACALL    rxrst     ; reset for next RX message
        SETB    PLLON     ; enable RX PLL
        CLR     TI        ; clear TI flag
        CLR     RI        ; clear RI flag
        SETB    ES        ; activate serial interrupts
rx_d:    RET              ; RX done

tick:    PUSH    PSW       ; push status
        PUSH    ACC       ; push accumulator
        MOV     C,RXPIN   ; read RX input pin
        MOV     RXISM,C    ; store as inverted RX sample
        JNB     TSFLG,tic0 ; skip if TX sample out idle
        MOV     A, TXSMC   ; else get sample count
        JZ      tic0      ; skip if 0
        MOV     C, TXBIT   ; else load TX bit
        MOV     TXPIN,C   ; into TX output pin
        DEC     TXSMC     ; decrement sample count
tic0:    JNB     PLLON,tic1 ; skip if PLL idle
        ACALL    pll      ; else run RX PLL
tic1:    JNB     TOFLG,tic2 ; skip if get message timeout idle
        INC     TMFCC     ; else bump timeout counter
        MOV     A, TMFCC   ; get counter
        CJNE   A,#50,tic2 ; skip if counter <> 50 (5.2 ms)
        CLR     TOFLG     ; else reset time out flag
        MOV     TMFCC,#0  ; reset counter
tic2:    INC     TXTL      ; bump TX timer low
        MOV     A, TXTL   ; load TX timer low
        JNZ    tick_d     ; done if no rollover
        JNB     ASFLG,tic3 ; skip if AutoSend idle
        DJNZ   TXTH,tick_d ; decrement TXTH, done if <> 0
        SETB   AMFLG     ; else set AM message flag
        MOV    TXTL,#0    ; clear TX delay low
        MOV    TXTH,#TXR0 ; reload TX delay high
        AJMP  tick_d     ; and jump to tic6
tic3:    JNB     TXFLG,tick_d ; skip if TX idle
        DJNZ   TXTH,tick_d ; decrement TXTH, done if <> 0
        SETB   TMFLG     ; else set TM message flag
        MOV    DPTR,#delay ; point to delay table
        MOV    A, TL1    ; get random table offset
        ANL   A,#07H    ; mask out upper 5 bits
        MOVC  A,@A+DPTR ; load byte from table
        MOV   TXTH,A     ; into TX delay high
        MOV   TXTL,#0    ; clear TX delay low

```

```

MOV      A, TXCNT      ; load retry count
CJNE    A, #9, tick_d  ; if <> 9 jump to tick_d
CLR     TMFLG         ; else reset send TX message
CLR     ANFLG         ; reset ACK/NAK flag (NAK)
SETB    SAFLG         ; set send ACK/NAK flag
CLR     TXFLG         ; reset TX active flag
tick_d: POP     ACC     ; pop accumulator
        POP     PSW    ; pop status
        RET     ; tick done

pll:    MOV     C, RXSMP ; load RX sample
        MOV     LRXSM, C ; into last RX sample
        MOV     C, RXISM ; get inverted RX sample
        CPL     C        ; invert sample
        MOV     RXSMP, C ; and store RX sample
        JNC    pll0     ; if <> 1 jump to pll0
        INC     RXID    ; else increment I&D
pll10:  JNB    LRXSM, pll1 ; if last sample 1
        CPL     C        ; invert current sample
pll11:  JNC    pll14     ; if no edge jump to pll14
        MOV     A, R2    ; else get PLL value
        CLR     C        ; clear borrow
        SUBB    A, #RMPS ; subtract ramp switch value
        JC     pll3     ; if < 0 then retard PLL
pll12:  MOV     A, R2    ; else get PLL value
        ADD     A, #RMPA ; add (RMPI + 5.625%)
        MOV     R2, A    ; store PLL value
        AJMP   pll15     ; and jump to pll15
pll13:  MOV     A, R2    ; get PLL value
        ADD     A, #RMPR ; add (RMPI - 5.625%)
        MOV     R2, A    ; store PLL value
        AJMP   pll15     ; and jump to pll15
pll14:  MOV     A, R2    ; get PLL value
        ADD     A, #RMPI ; add ramp increment
        MOV     R2, A    ; store new PLL value
pll15:  CLR     C        ; clear borrow
        MOV     A, R2    ; get PLL ramp value
        SUBB    A, #RMPT ; subtract ramp top
        JC     pllD     ; if < 0 don't wrap
pll16:  MOV     A, R2    ; else get PLL value
        CLR     C        ; clear borrow
        SUBB    A, #RMPW ; subtract reset value
        MOV     R2, A    ; and store result
        CLR     C        ; clear borrow
        MOV     A, RXID  ; get I&D buffer
        SUBB    A, #5    ; subtract 5
        JNC    pll17     ; if I&D count => 5 jump to pll17
        CLR     RXBIT    ; else RX bit = 0 for I&D count < 5
        SETB    RXBFLG  ; set new RX bit flag
        MOV     RXID, #0 ; clear the I&D buffer
        AJMP   pll18     ; and jump to pll18
pll17:  SETB    RXBIT    ; RX bit = 1 for I&D count => 5
        SETB    RXBFLG  ; set new RX bit flag
        MOV     RXID, #0 ; clear the I&D buffer
pll18:  JB     SOPFLG, pllA ; skip after SOP detect
        MOV     A, RXBH  ; else get RXBH
        CLR     C        ; clear carry
        RRC     A        ; rotate right
        JNB    RXBIT, pll9 ; if bit = 0 jump to pll9
        SETB    ACC.7    ; else set 7th bit
pll19:  MOV     RXBH, A   ; store RXBH
        MOV     A, RXBL  ; get RXBL
        RRC     A        ; shift and pull in carry
        MOV     RXBL, A  ; store RXBL
pll1A:  AJMP   pll_d     ; done for now
        MOV     A, RXBL  ; get RXBL
        CLR     C        ; clear carry
        RRC     A        ; shift right
        JNB    RXBIT, pllB ; if bit = 0 jump to pllB
        SETB    ACC.5    ; else set 5th bit
pll1B:  MOV     RXBL, A   ; store RXBL
        INC     RMSBC    ; bump bit counter
        MOV     A, RMSBC ; get counter
        CJNE    A, #6, pllC ; if <> 6 jump to pllC
        MOV     RXBB, RXBL ; else get symbol
        MOV     RMSBC, #0 ; reset counter
        SETB    RXSFLG  ; set symbol flag
pll1C:  AJMP   pll_d     ; done for now
pll1D:  CLR     RXBFLG  ; clear RXBFLG
pll_d:  RET     ; PLL done

```

```

rxsop:   JNB     RXBFLG,sop_d   ; done if no RX bit flag
         CLR     RXBFLG       ; else clear RX bit flag
         MOV     A,RXBL       ; get low RX buffer
         CJNE   A,#SOPL,sop_d ; done if <> SOPL
         MOV     A,RXBH       ; else get high RX buffer
         CJNE   A,#SOPH,sop_d ; done if <> SOPH
         CLR     A           ; else clear A
         MOV     RXBL,A       ; clear RX low buffer
         MOV     RXBH,A       ; clear RX high buffer
         MOV     RMSBC,A      ; clear RX symbol bit counter
         CLR     RXSFLG       ; clear RX symbol flag
         SETB   SOPFLG        ; set SOP detected flag
         CLR     RXI         ; RXI LED on
sop_d:   RET                 ; SOP detect done

rxmsg:   JNB     RXSFLG,rxmsg  ; wait for RX symbol flag
         CLR     RXSFLG       ; clear RX symbol flag
rxm1:    MOV     DPTR,#smb1    ; point to RX symbol decode table
         MOV     RMDC,#16     ; 16 symbol decode table entries
         MOV     RMBIC,#0     ; index into symbol table
rxm2:    MOV     A,RMBIC       ; load index into A
         MOVC   A,@A+DPTR     ; get table entry
         XRL   A,RXBB         ; XOR to compare with RXBB
         JZ     rxm3          ; exit loop with decoded nibble
         INC   RMBIC         ; else bump index
         DJNZ  RMDC,rxm2     ; and try to decode again
rxm3:    MOV     A,RMBIC       ; get decoded nibble
         SWAP  A             ; swap to high nibble
         MOV   RXBH,A        ; into RXBH (low nibble is high)
rxm4:    JNB     RXSFLG,rxm4   ; wait for symbol flag
         CLR     RXSFLG       ; clear flag
rxm5:    MOV     DPTR,#smb1    ; point to symbol decode table
         MOV     RMDC,#16     ; 16 symbol decode table entries
         MOV     RMBIC,#0     ; reset symbol table index
rxm6:    MOV     A,RMBIC       ; load index into A
         MOVC   A,@A+DPTR     ; get table entry
         XRL   A,RXBB         ; XOR to compare with RXBB
         JZ     rxm7          ; exit loop with decoded nibble
         INC   RMBIC         ; else bump index
         DJNZ  RMDC,rxm6     ; and try to decode again
rxm7:    MOV     A,RMBIC       ; get decoded nibble
         ORL   A,RXBH         ; add RXBH low
         SWAP  A             ; nibbles now in right order
         MOV   RXBH,A        ; store in RXBH
         MOV   @R0,RXBH      ; and store in RX message buffer
         CJNE  R0,#RXMB,rxm8 ; skip if not 1st message byte
         MOV   A,RXBH        ; else get 1st byte
         ANL  A,#63          ; mask upper 2 bits
         MOV   RMBYC,A       ; load message byte counter
         MOV   RMFCC,A       ; and RX message loop counter
         CLR  C              ; clear borrow
         SUBB A,#30          ; compare number of bytes to 30
         JC   rxm8           ; skip if < 30
         MOV  RMBYC,#4       ; else force byte counter to 4
         MOV  RMFCC,#4       ; and force loop counter to 4
rxm8:    INC   R0            ; bump pointer
         DJNZ RMFCC,rxmsg    ; if <> 0 get another byte
         MOV  R0,#RXMB       ; reset RX message pointer
rxm_d:   SETB   RXI         ; turn LED off
         RET                 ; RX message done

rxfcs:   MOV     RMFCC,RMBYC   ; move byte count to loop counter
rxf0:    MOV     RMFCS,@R0     ; get next message byte
         INC   R0            ; bump pointer
         ACALL b_rfcs         ; build FCS
         DJNZ RMFCC,rxf0     ; loop for next byte
         ACALL a_rfcs         ; test FCS
rxf_d:   RET                 ; RX FCS done

acktx:   MOV     A,RXMB       ; get 1st RX byte
         ANL  A,#64          ; mask ACK bit
         CJNE A,#64,atx_d    ; done if <> ACK
         MOV  A,TFBUF        ; else get TX TO/FROM
         SWAP A              ; swap for FROM/TO
         CJNE A,TFRX,atx_d   ; done if <> RX TO/FROM
         MOV  A,IDBUF        ; else get TX packet ID
         CJNE A,IDRX,atx_d   ; done if <> TX ID
         SETB ANFLG          ; else set ACK/NAK flag (ACK)
         SETB SAFLG         ; set send ACK/NAK message flag
         CLR  TXFLG         ; clear TX active flag
atx_d:   RET                 ; ACK TX done

```

```

ackrx:  MOV     A,TFBUF      ; get local TO/FROM address
        ANL     A,#15     ; mask to get local FROM address
        MOV     B,A       ; store FROM address
        MOV     A,TFRX    ; get T/F address from RX buffer
        SWAP   A         ; swap - FROM/TO
        ANL     A,#15     ; mask to get TO address
        CJNE   A,B,arx0   ; done if not to this node
        MOV     R1,#AKMB  ; load ACK pointer
        MOV     @R1,#69   ; ACK bit + 5 bytes
        MOV     TMFCS,#69 ; load TX message FCS byte
        ACALL  b_tfcs     ; and build FCS
        INC     R1        ; bump pointer
        MOV     A,TFRX    ; get TO/FROM byte
        SWAP   A         ; swap TO/FROM addresses
        MOV     @R1,A     ; add to ACK buffer
        MOV     TMFCS,A   ; load TX message FCS byte
        ACALL  b_tfcs     ; and build FCS
        INC     R1        ; bump pointer
        MOV     A,IDRX    ; get packet ID byte
        MOV     @R1,A     ; add ID to ACK message
        MOV     TMFCS,A   ; load TX message FCS byte
        ACALL  b_tfcs     ; and build FCS
        INC     R1        ; bump pointer
        ACALL  a_tfcs     ; add FCS
        MOV     R1,#AKMB  ; reset ACK pointer
        PUSH   TMBYC     ; push TX message TMBYC
        MOV     TMBYC,#5  ; 5 bytes in ACK
        ACALL  txpre     ; send TX preamble
        ACALL  txmsg     ; send TX message
        CLR     A         ; reset for next TX
        MOV     TMBYT,A   ; clear TX message byte
        MOV     TXSMC,A   ; clear TX out count
        MOV     TXSL,A   ; clear TX symbol low
        MOV     TXSH,A   ; clear TX symbol high
        MOV     R1,#TXMB  ; point R1 to message start
        POP    TMBYC     ; restore TX message TMBYC
arx0:   SETB   RFRCV     ; turn FCS LED off
arx_d:  RET              ; RX ACK done (rxsnd sets ES)

rxsnd:  CLR     PCRCV     ; turn PC LED on
        MOV     A,TFBUF   ; get local TO/FROM address
        ANL     A,#15     ; mask to get local FROM address
        MOV     B,A       ; store FROM address
        MOV     A,TFRX    ; get T/F address from RX buffer
        SWAP   A         ; swap - FROM/TO
        ANL     A,#15     ; mask to get TO address
        CJNE   A,B,rxs4   ; if <> don't send to host
        DEC    RMBYC     ; don't send
        DEC    RMBYC     ; the 2 FCS bytes
        MOV     R0,#RXMB  ; reset RX message pointer
        MOV     @R0,#FEND ; replace # bytes with 1st FEND
        JNB    NHFLG,rxs0 ; skip if no FEND/header flag reset
        INC    R0         ; bump past FEND
        DEC    RMBYC     ; decrement byte count
        INC    R0         ; bump past TO/FROM
        DEC    RMBYC     ; decrement byte count
        INC    R0         ; bump past ID
        DEC    RMBYC     ; decrement byte count
rxs0:   CLR     TI        ; clear TI flag
rxs1:   MOV     SBUF,@R0  ; send byte
rxs2:   JNB    TI,rxs2   ; wait until byte sent
        CLR    TI        ; clear TI flag
        INC    R0         ; bump pointer
        DJNZ  RMBYC,rxs1 ; loop to echo message
        JB    NHFLG,rxs4 ; skip if no FEND/header flag set
        MOV     SBUF,#FEND ; add 2nd FEND
rxs3:   JNB    TI,rxs3   ; wait until byte sent
        CLR    TI        ; clear TI flag
rxs4:   SETB   RFRCV     ; turn FCS LED off
        SETB   PCRCV     ; turn PC LED off
rxs_d:  RET              ; send RX message done

aksnd:  CLR     ES        ; disable serial interrupts
        CLR    PCRCV     ; turn PC LED on
        CLR    SAFLG     ; reset send ACK/NAK flag
        CLR    TXFLG     ; reset TX active flag
        MOV     A,IDBUF   ; get local ID
        ANL     A,#7      ; mask unused bits
        SWAP   A         ; swap ID to upper IDS nibble
        ADD    A,TXCNT    ; add retry count to IDS
        JNB    ANFLG,aks0 ; skip if NAK

```

```

aks0:   ADD     A,#128      ; else set ACK bit
        MOV     B,A      ; hold IDS in B
        MOV     A,TFBUF  ; get local TO/FROM
        SWAP   A         ; switch TO and FROM
        CLR     TI       ; clear TI flag
        MOV     SBUF,#FEND ; send 1st FEND
aks1:   JNB     TI,aks1   ; wait until byte sent
        CLR     TI       ; clear TI flag
        MOV     SBUF,A    ; send TO/FROM
aks2:   JNB     TI,aks2   ; wait until byte sent
        CLR     TI       ; clear TI flag
        MOV     SBUF,B    ; send IDS
aks3:   JNB     TI,aks3   ; wait until byte sent
        CLR     TI       ; clear TI flag
        MOV     SBUF,#FEND ; send 2nd FEND
aks4:   JNB     TI,aks4   ; wait until byte sent
        ACALL  txrst     ; reset TX state
        SETB   RFRCV    ; turn FCS LED off
        SETB   PCRCV    ; turn PC LED off
        CLR     TI       ; clear TI flag
        CLR     RI       ; clear RI flag
        SETB   ES       ; enable serial interrupts
aks_d:  RET              ; send ACK message done

rxrst:  CLR     A         ; clear A
        MOV     RXBH,A   ; clear buffer
        MOV     RXBL,A   ; clear buffer
        MOV     RXBB,A   ; clear buffer
        MOV     RMBYC,A  ; clear RX byte count
        MOV     RMFCC,A  ; clear loop counter
        MOV     R0,#RXMB ; point R0 to message start
        CLR     OKFLG    ; clear FCS OK flag
        CLR     SOPFLG   ; enable SOP test
        SETB   RXI      ; turn RXI LED off
rxr_d:  RET              ; RX reset done

brfcs:  MOV     RMLPC,#8  ; load loop count of 8
brf0:   CLR     C         ; clear carry bit
        MOV     A,RMFCS  ; load RX message byte
        RRC     A         ; shift lsb into carry
        MOV     RMFCS,A  ; store shifted message byte
        MOV     RM,C     ; load RM with lsb
        CLR     C         ; clear carry bit
        MOV     A,R3     ; load high FCS byte
        RRC     A         ; shift right
        MOV     R3,A     ; store shifted high FCS
        MOV     A,R7     ; load low FCS byte
        RRC     A         ; shift and pull in bit for FCS high
        MOV     R7,A     ; store shifted low FCS
        JNB    RM,brf1   ; if lsb of low FCS = 0, jump to brf1
        CPL     C         ; else complement carry bit
brf1:   JNC     brf2     ; if RM XOR (low FCS lsb) = 0 jump to brf2
        MOV     A,R3     ; else load high FCS
        XRL    A,#FCSH   ; and XOR with high FCS poly
        MOV     R3,A     ; store high FCS
        MOV     A,R7     ; load low FCS
        XRL    A,#FCSL   ; XOR with low FCS poly
        MOV     R7,A     ; store low FCS
brf2:   DJNZ   RMLPC,brf0 ; loop through bits in message byte
brfcs_d: RET              ; done this pass

arfcs:  MOV     A,R3     ; load FCS high
        XRL    A,#FCVH   ; compare with 0F0H
        JNZ    arf0     ; if <> 0 jump to arf0
        MOV     A,R7     ; load FCS low
        XRL    A,#FCVL   ; else compare with 0B8H
        JNZ    arf0     ; if <> 0 jump to arf0
        CLR     RFRCV    ; else turn FCS LED on
        SETB   OKFLG    ; set FCS OK flag
arf0:   MOV     R3,#FCSS  ; reseed FCS high
        MOV     R7,#FCSS  ; reseed FCS low
arfcs_d: RET              ; RX FCS done

srio:   PUSH   PSW       ; save
        PUSH   ACC       ; environment
        JNB   TI,sr_0    ; skip if not TI flag
        CLR   TI         ; else clear TI flag
sr_0:   JNB   RI,sr_1     ; skip if not RI flag
        CLR   RI         ; and clear RI flag
        JNB   SIFLG,sr_1 ; skip if serial in inactive
        CLR   PCRCV     ; else turn PC LED on

```

```

sr_1:    ACALL    do_tx      ; get & transmit message from host
        SETB    PCRCV    ; turn PC LED off
        POP     ACC       ; restore
        POP     PSW       ; environment
        RET

do_as:   CLR      PLLON    ; idle RX PLL
        ACALL   hello2    ; get AutoSend message
        ACALL   txfcs     ; build and add FCS
        ACALL   txpre     ; send TX preamble
        ACALL   txmsg     ; send TX message
        ACALL   txrst     ; reset TX
        SETB    PLLON    ; enable RX PLL
        RET

do_tx:   ACALL   txget    ; get TX message from host
        JNB    TXFLG,do1  ; skip if send TX idle
        CLR    PLLON    ; else idle RX PLL
        ACALL   txfcs     ; build and add FCS
        ACALL   txpre     ; send TX preamble
        ACALL   txmsg     ; send TX message
        INC    TXCNT     ; increment TX count
do1:     ACALL   txrst     ; reset TX
        SETB    PLLON    ; enable RX PLL
        RET

do_rt:   CLR      PLLON    ; idle RX PLL
        ACALL   txpre     ; send TX preamble
        ACALL   txmsg     ; send TX message
        INC    TXCNT     ; increment TX count
        ACALL   txrst     ; reset TX
        SETB    PLLON    ; enable RX PLL
        RET

txget:   MOV     A,SBUF    ; get byte
        MOV    TMBYT,A    ; copy to TMBYT
        XRL   A,#FEND    ; compare to FEND
        JZ    txg0       ; if FEND jump to txg0
        AJMP  txg_d      ; else done
txg0:    MOV    @R1,TMBYT  ; store 1st FEND
        INC   TMBYC      ; bump TX byte counter
txg1:    MOV    TMFCC,#0   ; reset timeout counter
        SETB  TOFLG      ; set timeout flag
        CLR   RI         ; clear RI flag
txg2:    JNB   TOFLG,txg3 ; if TOFLG reset jump to txg3
        JNB   RI,txg2    ; else loop until next byte
        CLR   RI         ; clear RI flag
        CLR   TOFLG      ; clear TOFLG
        AJMP  txg4       ; and jump to txg4
txg3:    MOV    TMBYC,#2   ; look like null message
        AJMP  txg6       ; and jump to txg6
txg4:    MOV    A,SBUF    ; get byte
        MOV    TMBYT,A    ; copy to TMBYT
        INC   TMBYC      ; bump byte counter
        INC   R1         ; bump pointer R1
        MOV    @R1,TMBYT  ; store byte
        MOV    A,TMBYC    ; load counter
        CLR   C          ; clear carry
        SUBB  A,#28       ; test for 28 bytes
        JZ    txg5       ; if 28 handle overflow at txg5
        MOV   A,TMBYT    ; else load byte
        CJNE  A,#FEND,txg1 ; if <> FEND loop to txg1
        AJMP  txg6       ; else jump to txg6 on 2nd FEND
txg5:    MOV    @R1,#FEND  ; force 2nd FEND
txg6:    MOV    R1,#TXMB  ; reset TX message pointer
        MOV    A,TMBYC    ; get byte count
        CJNE  A,#2,txg7  ; if <> 2 jump to txg7
        MOV    TMBYC,#0   ; else reset byte counter
        AJMP  txg_d      ; jump to txg_d
txg7:    CLR    SIFLG     ; idle serial_in
        CLR    TOFLG     ; clear timeout flag
        SETB   TXFLG     ; set TX active flag
        MOV    TFBUF,TFTX ; update local TO/FROM buffer
        MOV    IDBUF,IDTX ; update local ID buffer
        CLR    TI        ; clear TI flag
        MOV    SBUF,#FEND ; send 1st FEND
txg8:    JNB   TI,txg8   ; wait until byte sent
        CLR   TI        ; clear TI flag
        MOV    SBUF,#255  ; send PAK byte
txg9:    JNB   TI,txg9   ; wait until byte sent
        CLR   TI        ; clear TI flag

```

```

txgA:    MOV     SBUF,#FEND    ; send 2nd FEND
        JNB     TI,txgA      ; wait until byte sent
        CLR     TI           ; clear TI flag
txg_d:   RET                 ; get TX message done

txfcs:   INC     TMBYC       ; # bytes including FCS
        MOV     @R1,TMBYC    ; replace 1st FEND with # bytes
        MOV     TMFCC,TMBYC  ; move byte count to loop counter
        DEC     TMFCC       ; loop count is 2 less
        DEC     TMFCC       ; than # bytes including FCS
txf0:    MOV     TMFCS,@R1    ; get next message byte
        INC     R1           ; bump pointer
        ACALL  b_tfcs       ; build FCS
        DJNZ   TMFCC,txf0   ; loop for next byte
        ACALL  a_tfcs       ; add FCS
        MOV     R1,#TXMB    ; reset TX message pointer
        JB     ASFLG,txf1   ; skip if AutoSend
        MOV     DPTR,#delay  ; point to delay table
        MOV     A,TL1       ; get random table offset
        ANL    A,#07H      ; mask upper 5 bits
        MOVC   A,@A+DPTR    ; load table byte
        MOV     TXTH,A       ; into TX delay high
        AJMP   txf2         ; skip AutoSend delay
txf1:    MOV     TXTH,#TXR0  ; load AutoSend delay
txf2:    MOV     TXTL,#0     ; clear TX delay low
        SETB   TMFLG       ; set TX message flag
txf_d:   RET                 ; TX FCS done

txpre:   CLR     PTT         ; turn PTT on
        MOV     B,#200      ; load PTT delay count
txp0:    DJNZ   B,txp0       ; loop to delay
txp1:    MOV     DPTR,#tstrt  ; point to TX start table
        MOV     B,#0        ; clear B
        MOV     A,B         ; B holds table offset
        MOVC   A,@A+DPTR    ; load table entry
        MOV     TMBYT,A     ; into TMBYT
        MOV     TMBIC,#4    ; load bit count
        MOV     TXSMC,#0    ; clear sample count
        SETB   TSFLG       ; turn TX sample out on
txp2:    MOV     A,TXSMC    ; get sample count
        JNZ   txp2         ; loop until sample count 0
        MOV     A,TMBIC    ; get bit count
        JNZ   txp3         ; if <> 0 jump to txp3
        MOV     A,B         ; else get current offset (0 to 11)
        CLR    C           ; clear carry
        SUBB   A,#11       ; subtract ending offset
        JZ     txp_d       ; if 0 done
        INC   B            ; else bump byte count
        MOV   A,B          ; get count/offset
        MOVC  A,@A+DPTR    ; load table entry
        MOV   TMBYT,A     ; into TMBYT
        MOV   TMBIC,#4    ; reload bit count
txp3:    MOV     A,TMBYT    ; get TX message byte
        CLR    C           ; clear carry
        RRC   A           ; shift right into carry
        MOV   TXBIT,C     ; load next bit
        MOV   TMBYT,A     ; store shifted message byte
        DEC   TMBIC       ; decrement bit count
        MOV   TXSMC,#8    ; reload sample count
        AJMP  txp2        ; loop again
txp_d:   RET                 ; TX preamble done

txmsg:   MOV     B,#1        ; count 1st byte sent
        MOV     A,@R1       ; get 1st TX message byte
        MOV     TMBYT,A     ; into TMBYT
        MOV     DPTR,#smb1  ; point to symbol table
        ANL    A,#0FH      ; clean offset
        MOVC   A,@A+DPTR    ; get 6-bit symbol
        MOV     TXSL,A     ; move to TXSL
        MOV     A,TMBYT    ; get TMBYT
        SWAP  A           ; swap nibbles
        ANL    A,#0FH      ; clean offset
        MOVC   A,@A+DPTR    ; get 6-bit symbol
        MOV     TXSH,A     ; move to TXSH
        MOV     TMBIC,#12   ; set bit count to 12
        MOV     TXSMC,#0    ; clear sample count
txm0:    MOV     A,TXSMC    ; get sample count
        JNZ   txm0        ; loop until sample count 0
        MOV     A,TMBIC    ; get bit count
        CLR    C           ; clear carry
        SUBB   A,#7        ; subtract 7

```

```

JNC      txm1      ; if => 7 jump to txm1
MOV      A,TMBIC  ; else get bit count
JNZ      txm2      ; if > 0 jump to txm2
MOV      A,B       ; else get current byte number
CLR      C         ; clear carry
SUBB     A,TMBYC   ; subtract TX message byte count
JZ       txm3      ; if 0 done
INC      R1        ; else bump byte pointer
INC      B         ; and bump byte counter
MOV      A,@R1     ; get next byte
MOV      TMBYT,A   ; into TMBYT
MOV      DPTR,#smb1 ; point to symbol table
ANL      A,#0FH    ; offset
MOVC     A,@A+DPTR ; get 6-bit symbol
MOV      TXSL,A    ; move to TXSL
MOV      A,TMBYT   ; get TMBYT
SWAP     A         ; swap nibbles
MOV      DPTR,#smb1 ; point to symbol table
ANL      A,#0FH    ; clean offset
MOVC     A,@A+DPTR ; get 6-bit symbol
MOV      TXSH,A    ; move to TXSH
MOV      TMBIC,#12 ; set bit count to 12
txm1:    MOV      A,TXSL ; get low TX symbol
CLR      C         ; clear carry
RRC      A         ; shift right into carry
MOV      TXBIT,C   ; load next bit
MOV      TXSL,A    ; store shifted message byte
DEC      TMBIC     ; decrement bit count
MOV      TXSMC,#8  ; reload sample count
AJMP     txm0      ; loop again
txm2:    MOV      A,TXSH ; get high TX symbol
CLR      C         ; clear carry
RRC      A         ; shift right into carry
MOV      TXBIT,C   ; load next bit
MOV      TXSH,A    ; store shifted message byte
DEC      TMBIC     ; decrement bit count
MOV      TXSMC,#8  ; reload sample count
AJMP     txm0      ; loop again
txm3:    CLR      TSFLG ; clear TX sample out flag
CLR      TXPIN     ; clear TX out pin
SETB     PTT       ; turn PTT off
txm_d:   RET        ; TX message done

txrst:   CLR      TMFLG ; clear TX message flag
CLR      AMFLG     ; clear AutoSend message flag
CLR      A         ; reset for next TX
MOV      TMBYT,A   ; clear TX message byte
MOV      TMFCC,A   ; clear TX FCS count
MOV      TXSMC,A   ; clear TX out count
MOV      TXSL,A    ; clear TX symbol low
MOV      TXSH,A    ; clear TX symbol high
MOV      R1,#TXMB ; point R1 to message start
JB       ASFLG,txr_d ; skip if in AutoSend
JB       TXFLG,txr_d ; skip if send TX active
MOV      TMBYC,A   ; reset TX message byte count
MOV      TXCNT,A   ; reset TX retry count
MOV      TXTL,A    ; clear TX timer low
MOV      TXTH,A    ; clear TX timer high
SETB     SIFLG     ; enable serial in
txr_d:   RET        ; TX reset done

b_tfcs:  MOV      B,#8 ; load loop count of 8
btff0:   CLR      C         ; clear carry bit
MOV      A,TMFCS   ; load TX message byte
RRC      A         ; shift lsb into carry
MOV      TMFCS,A   ; store shifted message byte
MOV      TM,C      ; load TM with lsb
CLR      C         ; clear carry bit
MOV      A,R5     ; load high FCS byte
RRC      A         ; shift right
MOV      R5,A     ; store shifted high FCS
MOV      A,R6     ; load low FCS byte
RRC      A         ; shift and pull in bit for FCS high
MOV      R6,A     ; store shifted low FCS
JNB     TM,btff1  ; if lsb of low FCS = 0, jump to btff1
CPL     C         ; else complement carry bit
btff1:   JNC     btff2 ; if TM XOR (low FCS lsb) = 0 jump to btff2
MOV      A,R5     ; else load high FCS
XRL     A,#FCSH   ; and XOR with high FCS poly
MOV      R5,A     ; store high FCS
MOV      A,R6     ; load low FCS

```

```

        XRL      A,#FCSL      ; XOR with low FCS poly
        MOV      R6,A         ; store low FCS
btf2:   DJNZ    B,btf0       ; loop through bits in message byte
btfcs_d: RET                  ; done this pass

a_tfcs: MOV      A,R6         ; load FCS (high/low switch)
        CPL      A           ; 1's complement
        MOV      @R1,A       ; store at end of TX message
        INC      R1          ; increment TX message byte pointer
        MOV      A,R5         ; load FCS (high/low switch)
        CPL      A           ; 1's complement
        MOV      @R1,A       ; store at end of TX message
        MOV      R5,#FCSS    ; reseed FCS high
        MOV      R6,#FCSS    ; reseed FCS low
atfcs_d: RET                  ; add TX FCS done

setup:  CLR      EA           ; disable interrupts
        SETB    PTT          ; turn PTT off
        CLR      TXPIN       ; turn TX modulation off
tick_su: MOV     TMOD,#ITMOD  ; set timers T0 and T1 to mode 2
        CLR      TR0         ; stop timer T0
        CLR      TF0         ; clear T0 overflow
        MOV      TH0,#ITICK  ; load count for 62.40 us tick
        MOV      TLO,#ITICK  ; load count for 62.40 us tick
        SETB    TR0         ; start timer T0
        SETB    ETO         ; unmask T0 interrupt
uart_su: SETB    MAX         ; power up Maxim RS232 converter
        CLR      TR1         ; stop timer T1
        CLR      TF1         ; clear T1 overflow
        MOV      TH1,#IBAUD  ; load baud rate count
        MOV      T1L,#IBAUD  ; load baud rate count
        MOV      PCON,#ISMOD ; SMOD = 1 for baud rate @ 22.1184 MHz
        SETB    TR1         ; start baud rate timer T1
        MOV      SCON,#ISCON ; enable UART mode 1
        MOV      A,SBUF      ; clear out UART RX buffer
        CLR      A           ; clear A
        CLR      RI          ; clear RI (byte received) flag
        CLR      TI          ; clear TI (byte sent) flag
        ACALL   hello       ; send start up message
        ACALL   initr       ; initialize TX & RX
        MOV      TXTH,#TXR0  ; load default AutoSend delay
        SETB    SIFLG       ; set serial in flag active
        MOV      C,ID3       ; read ID3
        JC      as_set      ; skip if no ID3 jumper
        SETB    NHFLG       ; else set no FEND/header flag
as_set: MOV      C,ID0       ; read ID0
        JC      ser_on      ; skip if no ID0 jumper
        ACALL   hello2      ; else do AutoSend
ser_on:  SETB    ES          ; enable serial ISR
isr_on:  SETB    EA          ; enable interrupts
        SETB    PLLON       ; activate RX PLL
setup_d: RET                  ; setup done

initr:  ANL      BOOT,#1     ; warm boot (don't reset WBFLG)
        MOV      R0,#35     ; starting here
        MOV      B,#93      ; for 93 bytes
        CLR      A           ; clear A
clr_r:  MOV      @R0,A       ; clear RAM
        INC      R0          ; bump RAM pointer
        DJNZ    B,clr_r     ; loop again
        MOV      R0,#RXMB   ; load RX buffer pointer
        MOV      R1,#TXMB   ; load TX buffer pointer
        MOV      R2,A       ; clear R2
        MOV      R3,#FCSS   ; seed R3
        MOV      R5,#FCSS   ; seed R5
        MOV      R6,#FCSS   ; seed R6
        MOV      R7,#FCSS   ; seed R7
        MOV      TFBUF,#34  ; initialize TO/FROM 2 & 2
        MOV      IDBUF,#3   ; initialize ID = 3
        CLR      SOPFLG     ; clear SOPFLG
        SETB    PT0         ; tick is 1st priority
ini_d:  RET                  ; done

hello:  MOV      DPTR,#table ; point to table
        MOV      B,#13      ; load loop count in B
        MOV      R7,#0      ; R7 has 1st table entry
snd_h:  MOV      A,R7        ; move table offset into A
        MOVC   A,@A+DPTR    ; load table byte
        CLR      TI          ; clear TI flag
        MOV      SBUF,A     ; send byte

```

```

nxt_tx:   JNB     TI,nxt_tx   ; wait until sent
          INC     R7          ; bump index
          DJNZ   B,snd_h     ; loop to send message
hello_d:  RET                ; done

hello2:   MOV     DPTR,#tbl_2 ; point to table 2
          MOV     R1,#TXMB_2  ; reset TX buffer pointer
          MOV     B,#10       ; loop count for 9 bytes
          MOV     TMBYC,#0    ; offset for 1st table entry
snd_h2:   MOV     A,TMBYC     ; move table offset into A
          MOVC   A,@A+DPTR   ; load table byte
          MOV     @R1,A       ; into TX buffer
          INC     TMBYC      ; increment TMBYC
          INC     R1          ; increment R1
          DJNZ   B,snd_h2    ; loop to load message
          MOV     R1,#TXMB    ; reset TX pointer
          CLR     SIFLG      ; reset serial input
          SETB   ASFLG      ; set AutoSend flag
hello2_d  RET

; tables:

tstrt:   .BYTE   10          ; preamble/SOP table
          .BYTE   10          ; table data
          .BYTE   10          ; table data
          .BYTE   10          ; table data
          .BYTE   10          ; table data
          .BYTE   10          ; table data
          .BYTE   10          ; table data
          .BYTE   10          ; table data
          .BYTE   8           ; table data
          .BYTE   3           ; table data
          .BYTE   11          ; table data

smb1:    .BYTE   13          ; 4-to-6 bit table
          .BYTE   14          ; table data
          .BYTE   19          ; table data
          .BYTE   21          ; table data
          .BYTE   22          ; table data
          .BYTE   25          ; table data
          .BYTE   26          ; table data
          .BYTE   28          ; table data
          .BYTE   35          ; table data
          .BYTE   37          ; table data
          .BYTE   38          ; table data
          .BYTE   41          ; table data
          .BYTE   42          ; table data
          .BYTE   44          ; table data
          .BYTE   50          ; table data
          .BYTE   52          ; table data
          .BYTE   00          ; overflow

delay:   .BYTE   020H        ; 0.50 second
          .BYTE   044H        ; 1.10 second
          .BYTE   032H        ; 0.80 second
          .BYTE   058H        ; 1.40 second
          .BYTE   028H        ; 0.65 second
          .BYTE   04EH        ; 1.25 second
          .BYTE   03CH        ; 0.95 second
          .BYTE   062H        ; 1.55 second

table:   .BYTE   192         ; start up message
          .BYTE   34          ; table data
          .BYTE   3           ; table data
          .BYTE   'D'         ; table data
          .BYTE   'K'         ; table data
          .BYTE   '2'         ; table data
          .BYTE   '0'         ; table data
          .BYTE   '0'         ; table data
          .BYTE   'A'         ; table data
          .BYTE   ':'         ; table data
          .BYTE   ' '         ; table data
          .BYTE   ' '         ; table data
          .BYTE   192         ; table data

tbl_2:   .BYTE   192         ; table data
          .BYTE   34          ; table data
          .BYTE   3           ; table data
          .BYTE   'H'         ; table data
          .BYTE   'e'         ; table data

```

```

.BYTE      '1'           ; table data
.BYTE      '1'           ; table data
.BYTE      'o'           ; table data
.BYTE      ' '           ; table data
.BYTE      192           ; table data

.END                ; end of source code

```

5.2 V110T30C.FRM

```

VERSION 5.00
Object = "{648A5603-2C6E-101B-82B6-000000000014}#1.1#0"; "MSCOMM32.OCX"
Object = "{F9043C88-F6F2-101A-A3C9-08002B2F49FB}#1.2#0"; "COMDLG32.OCX"
Object = "{831FDD16-0C5C-11D2-A9FC-0000F8754DA1}#2.0#0"; "MSCOMCTL.OCX"
Begin VB.Form Form1
    Caption           = "V110T30C Terminal Program for DK200A Protocol - 2002.08.07 Rev"
    ClientHeight      = 5235
    ClientLeft        = 225
    ClientTop         = 630
    ClientWidth       = 7785
    LinkTopic         = "Form1"
    MaxButton         = 0           'False
    ScaleHeight       = 5951.697
    ScaleMode         = 0           'User
    ScaleWidth        = 7905
    Begin MSComctlLib.ProgressBar ProgressBar1
        Height        = 251
        Left          = 1162
        TabIndex      = 3
        Top           = 4934
        Width         = 4875
        _ExtentX      = 8599
        _ExtentY      = 450
        _Version      = 393216
        Appearance    = 0
        Scrolling     = 1
    End
    Begin MSComctlLib.StatusBar StatusBar1
        Align         = 2           'Align Bottom
        Height        = 375
        Left          = 0
        TabIndex      = 2
        Top           = 4860
        Width         = 7785
        _ExtentX      = 13732
        _ExtentY      = 661
        _Version      = 393216
        BeginProperty Panels {8E3867A5-8586-11D1-B16A-00C0F0283628}
            NumPanels = 4
            BeginProperty Panel1 {8E3867AB-8586-11D1-B16A-00C0F0283628}
                Alignment = 1
                Bevel     = 0
                Object.Width = 148
                MinWidth  = 148
            EndProperty
            BeginProperty Panel2 {8E3867AB-8586-11D1-B16A-00C0F0283628}
                Alignment = 1
                Object.Width = 1737
                MinWidth  = 1737
                Text       = "TX Buffer"
                TextSave  = "TX Buffer"
            EndProperty
            BeginProperty Panel3 {8E3867AB-8586-11D1-B16A-00C0F0283628}
                Object.Width = 8755
                MinWidth  = 8755
            EndProperty
            BeginProperty Panel4 {8E3867AB-8586-11D1-B16A-00C0F0283628}
                Alignment = 1
                Text       = "Keyboard"
                TextSave  = "Keyboard"
            EndProperty
        EndProperty
    End
    Begin MSComDlg.CommonDialog CommonDialog1
        Left      = 240
        Top       = 4320
        _ExtentX  = 688
        _ExtentY  = 688
    End

```

```

    _Version      = 393216
End
Begin VB.TextBox Text2
    Height        = 2323
    Left         = 148
    Locked        = -1 `True
    MultiLine     = -1 `True
    ScrollBars    = 2 `Vertical
    TabIndex     = 1
    Top          = 0
    Width        = 7460
End
Begin VB.Timer Timer1
    Left         = 720
    Top          = 4320
End
Begin MSCommLib.MSComm MSComm1
    Left        = 1200
    Top         = 4320
    _ExtentX   = 794
    _ExtentY   = 794
    _Version   = 393216
    DTREnable  = -1 `True
End
Begin VB.TextBox Text1
    Height        = 2323
    Left         = 120
    MultiLine     = -1 `True
    ScrollBars    = 2 `Vertical
    TabIndex     = 0
    Top          = 2513
    Width        = 7460
End
Begin VB.Menu mnuFile
    Caption      = "&File"
    Begin VB.Menu mnuExit
        Caption  = "E&xit"
    End
End
Begin VB.Menu mnuEdit
    Caption      = "&Edit"
    Begin VB.Menu mnuToAdr
        Caption  = "To Address"
        Begin VB.Menu mnuTN1
            Caption = "Node 1"
        End
        Begin VB.Menu mnuTN2
            Caption = "Node 2"
            Checked = -1 `True
        End
        Begin VB.Menu mnuTN3
            Caption = "Node 3"
        End
        Begin VB.Menu mnuTN4
            Caption = "Node 4"
        End
    End
    Begin VB.Menu mnuFrmAdr
        Caption  = "From Address"
        Begin VB.Menu mnuFN1
            Caption = "Node 1"
        End
        Begin VB.Menu mnuFN2
            Caption = "Node 2"
            Checked = -1 `True
        End
        Begin VB.Menu mnuFN3
            Caption = "Node 3"
        End
        Begin VB.Menu mnuFN4
            Caption = "Node 4"
        End
    End
End
Begin VB.Menu mnuView
    Caption      = "&View"
    Begin VB.Menu mnuClear
        Caption  = "&Clear"
    End
End

```

```

Begin VB.Menu mnuDups
    Caption      = "Show RX &Dups"
    Checked      = -1 'True
End
Begin VB.Menu mnuShw
    Caption      = "&Show ACK/NAK"
    Checked      = -1 'True
End
Begin VB.Menu mnuAutoSnd
    Caption      = "&AutoSend"
End
End
End
Attribute VB_Name = "Form1"
Attribute VB_GlobalNameSpace = False
Attribute VB_Creatable = False
Attribute VB_PredeclaredId = True
Attribute VB_Exposed = False

` V110T30C.FRM, 2002.08.07 @ 08:00 CDT
` See RFM Virtual Wire(r) Development Kit Warranty & License for terms of use
` Tutorial software - NO representation is made that this software
` is suitable for any purpose
` Copyright(c) 2000-2002, RF Monolithics, Inc.
` For experimental use with the RFM DR1200A-DK and DR1201A-DK
` and DR1300A-DK ASH Transceiver Virtual Wire(R) Development Kits
` For protocol software version DK200A.ASM
` Check www.rfm.com for latest software updates
` Compiled in Microsoft Visual Basic 6.0

` global variables:
Dim ComData$           ` com input string
Dim ComTime!           ` com input reference time
Dim KeyIn$             ` keystroke input buffer
Dim TXFlag As Integer  ` send TX message flag
Dim TNFlag As Integer  ` send next TX packet flag
Dim TPkt$              ` keyboard input string
Dim TSPkt$             ` SLIP encoded input string
Dim TXPkt$             ` transmit message string
Dim SPkt$              ` transmit packet string
Dim TFlag As Integer   ` packet transfer flag
Dim ANFlag As Integer  ` ACK/NAK flag
Dim TCnt As Integer    ` TX timeout counter
Dim XCnt As Integer    ` TX transfer retry counter
Dim Temp$              ` temp string buffer
Dim Temp1$             ` temp1 string buffer
Dim FRM As Integer     ` RX From address
Dim ID As Integer      ` RX packet ID
Dim DupFltr As Integer ` duplicate RX filter flag
Dim PID(15) As Integer ` packet ID array (dup/skip detector)
Dim DpSkp As Integer   ` dup/skip status
Dim pSLIP As Integer   ` SLIP pointer
Dim G As Integer       ` ID compare
Dim I As Integer       ` general purpose index/counter
Dim K As Integer       ` SLIP encoded packet length
Dim N As Integer       ` keyboard byte counter
Dim P As Integer       ` TX packet ID #, 1 - 7
Dim FEND$              ` SLIP framing character
Dim ESC$               ` SLIP escape character
Dim TFEND$             ` SLIP transpose frame
Dim TESC$              ` SLIP transpose escape
Dim PktHdr$           ` packet header
Dim J As Integer       ` FEND$ string position
Dim Q As Integer       ` RPkt$ length
Dim RPkt$              ` RX message FIFO string
Dim R2Pkt$            ` RX message display string
Dim ASFlag As Integer  ` AutoSend enable flag
Dim NAFlag As Integer  ` AutoSend next message flag
Dim InDel!            ` delay for com input
Dim PCnt As Integer    ` packet TX tries counter
Dim ShwACK As Integer  ` show ACK/NAK flag
Dim TNode As Integer   ` To node numeric value
Dim FNode As Integer   ` From node numeric value
Dim TF As Integer      ` To/From node numeric value
Dim ASStr$            ` AutoSend string

Private Sub Form_Load()

` initialize variables:
ComData$ = ""           ` clear string
ComTime! = 0           ` clear reference time

```

```

KeyIn$ = ""
TXFlag = 0
TNFlag = 0
TPkt$ = ""
TSPkt$ = ""
TXPkt$ = ""
SPkt$ = ""
TFlag = 0
ANFlag = 0
TCnt = 0
XCnt = 0
Temp$ = ""
Temp1$ = ""
FRM = 0
ID = 0
DupFltr = 0
pSLIP = 0
G = 0
I = 0
K = 0
N = 0
P = 3
FEND$ = Chr$(192)
ESC$ = Chr$(219)
TFEND$ = Chr$(220)
TESC$ = Chr$(221)
PktHdr$ = Chr$(34)
J = 0
Q = 0
RPkt$ = ""
R2Pkt$ = ""
ASFlag = 0
NAFlag = 0
PCnt = 0
ShwACK = 1
TNode = 2
FNode = 2
TF = 34
For B = 0 To 15
    PID(B) = -1
Next B

ASStr$ = "***Auto Test Message**" & vbCrLf

Form1.Left = (Screen.Width - Form1.Width) / 2
Form1.Top = (Screen.Height - Form1.Height) / 2
Text1.BackColor = QBColor(0)
Text1.ForeColor = QBColor(15)
Text1.FontSize = 10
Text2.BackColor = QBColor(0)
Text2.ForeColor = QBColor(15)
Text2.FontSize = 10

MSComm1.CommPort = 1
MSComm1.Settings = "19200,N,8,1"
MSComm1.RThreshold = 0
MSComm1.InputLen = 0
MSComm1.PortOpen = True
InDel! = 0.1

StatusBar1.Panels(4).Text = "Keyboard Active"
ProgressBar1.Min = 0
ProgressBar1.Max = 240

Show
Text1.Text = "***TX Message Window**" & vbCrLf
Text1.Text = Text1.Text & "***Set for Node 2 & 2**" _
    & vbCrLf & vbCrLf
Text1.SelStart = Len(Text1.Text)
Text2.Text = "***RX Message Window**" & vbCrLf
Text2.SelStart = Len(Text2.Text)

Randomize

Timer1.Interval = 300
Timer1.Enabled = True

End Sub

```

```

\ clear keystroke buffer
\ clear TX message flag
\ clear next TX packet flag
\ clear TX packet string
\ clear SLIP encoded string
\ clear TX message string
\ clear send packet string
\ clear transfer flag
\ clear ACK/NAK flag
\ clear TX timeout counter
\ clear transfer counter
\ clear temp string buffer
\ clear 2nd temp string buffer
\ set RX From to 0
\ set RX packet ID to 0
\ clear duplicate filter
\ clear SLIP pointer
\ clear ID compare
\ clear index/counter
\ clear SLIP packet length
\ clear keyboard byte counter
\ set packet ID to 3
\ initialize SLIP framing character
\ initialize SLIP escape character
\ initialize SLIP transpose frame
\ initialize SLIP transpose escape
\ set To/From default = 2/2
\ clear string position
\ clear string length
\ clear RX FIFO string
\ clear RX display string
\ clear AutoSend flag
\ clear next AutoSend flag
\ clear TX tries counter
\ set show ACK/NAK flag
\ set To node default = 2
\ set From node default = 2
\ set TF default = 34
\ set PID array elements = -1

\ default AutoSend message

\ center form left-right
\ center form top-bottom
\ black background
\ white letters
\ 10 point font
\ black background
\ white letters
\ 10 point font

\ initialize com port
\ at 19.2 kbps
\ poll only, no interrupts
\ read all bytes
\ open com port
\ initialize get com delay at 100 ms

\ keyboard active status message
\ progress bar min number of TX bytes
\ progress bar max number of TX bytes

\ show form
\ 1st line of TX start up message
\ 2nd line of TX start up message
\ put cursor at end of text
\ RX start up message
\ put cursor at end of text

\ initialize random # generator

\ 300 ms timer interval
\ start timer

```

```

Private Sub Timer1_Timer()
    If ANFlag = 1 Then
        Call Xfer
    End If
    If MSComm1.InBufferCount > 0 Then
        Call RxPkt
    End If
    If TXFlag = 1 Then
        If TNFlag = 1 Then
            Call SndPkt
        End If
    End If
    If ASFlag = 1 Then
        If TXFlag = 0 Then
            Call ASPkt
        End If
    End If
End Sub

Public Sub RxPkt()
    Call InCom
    Call ShowPkt
End Sub

Public Sub InCom()
    On Error Resume Next
    ComTime! = Timer
    Do Until Abs(Timer - ComTime!) > InDel!
        Do While MSComm1.InBufferCount > 0
            ComData$ = ComData$ & MSComm1.Input
        Loop
    Loop
End Sub

Public Sub ShowPkt()
    RPkt$ = RPkt$ & ComData$
    ComData$ = ""
    Do
        Q = Len(RPkt$)
        J = InStr(1, RPkt$, FEND$)
        If (J < 2) Then
            RPkt$ = Right$(RPkt$, (Q - J))
        Else
            R2Pkt$ = Left$(RPkt$, (J - 1))
            RPkt$ = Right$(RPkt$, (Q - J))
            If Len(R2Pkt$) = 1 Then
                If (R2Pkt$ = Chr$(255)) Then
                    TFlag = 0
                    If ShwACK = 1 Then
                        Call LenTrap
                        Text1.SelStart = Len(Text1.Text)
                        Text1.SelText = "<Xfer on try " &
                            & Str(XCnt + 1) & "> "
                    End If
                    R2Pkt$ = ""
                End If
            ElseIf Len(R2Pkt$) = 2 Then
                ANFlag = 0
                NAFlag = 0
                TNFlag = 1
                Temp$ = Str((Asc(Left$(R2Pkt$, 1)) And &HF))
                Temp1$ = Str((Int(Asc(Mid$(R2Pkt$, 2, 1)) / 16)) &
                    And &H7)
                If (Asc(Right$(R2Pkt$, 1)) And &H80) = 128 Then
                    PCnt = (Asc(Right$(R2Pkt$, 1)) And &HF)
                    If ShwACK = 1 Then
                        Call LenTrap
                        Text1.SelStart = Len(Text1.Text)
                        Text1.SelText = "<ACK from N" &
                            & Temp$ & " : P" & Temp1$ & " on " &
                            & Str(PCnt) & ">" & vbCrLf
                    End If
                    R2Pkt$ = ""
                Else
                    If ShwACK = 1 Then
                        Call LenTrap
                        Text1.SelStart = Len(Text1.Text)
                        Text1.SelText = "<NAK from N" &
                            & Temp$ & " : P" & Temp1$ & ">" & vbCrLf
                    End If
                End If
            End Do
        Loop
    End Sub

' if ACK/NAK flag set
' call Xfer (detect switch OFF, etc.)

' if com input buffer has bytes
' call RxPkt

' if TX message flag set
' and next TX packet flag set
' call SndPkt

' if AutoSend flag set
' and TX message flag clear
' call AutoSend

' InCom gets RX message bytes
' ShowPkt shows RX message bytes

' set up error handler
' get current time
' get bytes for InDel! interval
' while bytes are in com buffer
' put them in ComData$

' add ComData$ bytes to RPkt$ FIFO
' and clear ComData$
' do until FEND$$ are gone
' Q is RPkt$ packet length
' find position of next FEND$
' if FEND$ is in the first position
' just delete it
' else
' R2Pkt$ what's left of this FEND$
' RPkt$ what's right of this FEND$
' only PAC is a 1 byte message
' if PAC byte
' reset transfer flag
' if show ACK/NAK flag set
' manage textbox memory
' put cursor at end of text
' show try number for transfer
' and clear R2Pkt$

' only ACK/NAK are 2 byte messages
' reset ACK/NAK flag
' reset next AutoSend flag
' set next TX packet flag
' get From address
' get packet ID number
' if ACK bit set
' get ACK retry number
' if show ACK/NAK flag set
' manage textbox memory
' put cursor at end of text
' show ACK From, ID and retry number
' and clear R2Pkt$

' if show ACK/NAK flag set
' manage textbox memory
' put cursor to end of text
' show NAK received

```

```

R2Pkt$ = "" ' and clear R2Pkt$
End If
ElseIf Len(R2Pkt$) > 2 Then ' other messages are > 2 bytes
Do ' decode FEND$ escape sequences
  pSLIP = InStr(R2Pkt$, (ESC$ & TFEND$)) ' find position of next ESC$ & TFEND$
  If pSLIP <> 0 Then ' if (ESC$ & TFEND$) present
    K = Len(R2Pkt$)
    If K >= (pSLIP + 2) Then ' if escape sequence not last bytes
      R2Pkt$ = Left$(R2Pkt$, (pSLIP - 1)) & FEND$ ' replace escape sequence with FEND$
      & Mid$(R2Pkt$, (pSLIP + 2))
    Else ' else replace with FEND$ at end
      R2Pkt$ = Left$(R2Pkt$, (pSLIP - 1)) & FEND$
    End If
  Else
    Exit Do ' else done
  End If
Loop
Do ' decode ESC$ escape sequences
  pSLIP = InStr(R2Pkt$, (ESC$ & TESC$)) ' find position of next ESC$ & TESC$
  If pSLIP <> 0 Then ' if (ESC$ & TESC$) string(s) present
    I = Len(R2Pkt$)
    If I >= (pSLIP + 2) Then ' if escape sequence not last bytes
      R2Pkt$ = Left$(R2Pkt$, (pSLIP - 1)) & ESC$ ' replace escape sequence with ESC$
      & Mid$(R2Pkt$, (pSLIP + 2))
    Else ' else replace with ESC$ at end
      R2Pkt$ = Left$(R2Pkt$, (pSLIP - 1)) & ESC$
    End If
  Else
    Exit Do ' else done
  End If
Loop
FRM = Asc(Left$(R2Pkt$, 1)) And &HF ' get RX packet From address
ID = Asc(Mid$(R2Pkt$, 2, 1)) And &H7 ' get RX packet ID
Call ChkPkt ' check packet for skip/dup
If DpSkp <> 0 Or DupFltr = 0 Then ' if not dup or dup filter off
  If ShwACK = 1 Then ' if show ACK/NAK flag set
    Temp$ = Str(FRM) ' make From address string
    Temp1$ = Str(ID) ' make packet ID string
    R2Pkt$ = Right$(R2Pkt$, (Len(R2Pkt$) - 2)) ' strip off TO/FROM and ID bytes
    If Right$(R2Pkt$, 2) = vbCrLf Then ' check for vbCrLf
      R2Pkt$ = Left$(R2Pkt$, (Len(R2Pkt$) - 2)) ' remove vbCrLf if present
    ElseIf Right$(R2Pkt$, 1) = Chr$(13) Then ' also check for a trailing Cr
      R2Pkt$ = Left$(R2Pkt$, (Len(R2Pkt$) - 1)) ' remove Cr if present
    End If
    If Left$(R2Pkt$, 1) = Chr$(10) Then ' check for a leading Lf
      R2Pkt$ = Right$(R2Pkt$, (Len(R2Pkt$) - 1)) ' remove Lf if present
    End If
    Call LenTrap ' manage textbox memory
    If DpSkp = 1 Then ' if skipped packet(s) detected
      Text2.SelStart = Len(Text2.Text) ' put cursor at end of text
      Text2.SelText = " [PID Skip] " ' show where skip(s) occurred
    End If
    Text2.SelStart = Len(Text2.Text) ' put cursor at end of text
    Text2.SelText = R2Pkt$ & " <from N" ' show message, From, ID, new line
    & Temp$ & " : P" & Temp1$ & ">" & vbCrLf ' and clear R2Pkt$
    R2Pkt$ = ""
  Else
    R2Pkt$ = Right$(R2Pkt$, (Len(R2Pkt$) - 2)) ' else strip off TO/FROM and ID bytes
    Call LenTrap ' manage textbox memory
    If DpSkp = 1 Then ' if skipped packet(s) detected
      Text2.SelStart = Len(Text2.Text) ' put cursor at end of text
      Text2.SelText = " [PID Skip] " ' show where skip(s) occurred
    End If
    Text2.SelStart = Len(Text2.Text) ' put cursor at end of text
    Text2.SelText = R2Pkt$ ' show message
    R2Pkt$ = "" ' and clear R2Pkt$
  End If
End If
End If
End If
Loop Until (J = 0) ' done when there are no more FEND$s
End Sub

Public Sub ChkPkt()
  G = PID(FRM) ' G is last stored ID
  If G = -1 Then ' if -1 it's the first check
    DpSkp = -1 ' so signal no skip/dup
  ElseIf G = ID Then ' else if G = ID it's a dup
    DpSkp = 0 ' signal dup
  Else ' else if G <> to ID
    G = G + 1 ' increment G
  End If
End Sub

```

```

    If G > 7 Then
        G = 0
    End If
    If G = ID Then
        DpSkp = -1
    Else
        DpSkp = 1
    End If
End If
PID(FRM) = ID
End Sub

Private Sub Text1_KeyPress(KeyAscii As Integer)
    If TXFlag = 0 Then
        KeyIn$ = Chr$(KeyAscii)
        If KeyIn$ = Chr$(8) Then
            If N > 0 Then
                TPkt$ = Left$(TPkt$, (N - 1))
                N = N - 1
            End If
        ElseIf KeyIn$ = Chr$(13) Then
            TPkt$ = TPkt$ & vbCrLf
            ASStr$ = TPkt$
            N = 0
            TXFlag = 1
            TNFlag = 1
            StatusBar1.Panels(4).Text = "Keyboard Locked"
        Else
            TPkt$ = TPkt$ & KeyIn$
            N = N + 1
        End If
        If (N = 238) Then
            TPkt$ = TPkt$ & vbCrLf
            ASStr$ = TPkt$
            Text1.SelStart = Len(Text1.Text)
            Text1.SelText = KeyIn$ & vbCrLf
            KeyAscii = 0
            N = 0
            TXFlag = 1
            TNFlag = 1
            StatusBar1.Panels(4).Text = "Keyboard Locked"
        End If
        Call LenTrap
    Else
        KeyAscii = 0
    End If
End Sub

Public Sub SndPkt()
    If TNFlag = 1 Then
        If TPkt$ <> "" Then
            L = Len(TPkt$)
            For I = 1 To L
                Temp$ = Mid$(TPkt$, I, 1)
                If Temp$ = FEND$ Then
                    TSPkt$ = TSPkt$ & ESC$ & TFEND$
                ElseIf Temp$ = ESC$ Then
                    TSPkt$ = TSPkt$ & ESC$ & TESC$
                Else
                    TSPkt$ = TSPkt$ & Temp$
                End If
            Next I
            TXPkt$ = TXPkt$ & TSPkt$
            TPkt$ = ""
            TSPkt$ = ""
        End If
        If Int(4 * Rnd) > 0 Then
            TNFlag = 0
            L = Len(TXPkt$)
            If L <= 240 Then
                ProgressBar1.Value = L
            Else
                ProgressBar1.Value = 240
            End If
            If L > 0 Then
                If L > 24 Then
                    SPkt$ = Left$(TXPkt$, 24)
                    TXPkt$ = Right$(TXPkt$, (L - 24))
                Else
                    SPkt$ = TXPkt$
                    TXPkt$ = ""
                End If
            End If
        End If
    End If
End Sub

```

```

\ if greater than 7
\ reset to 0
\ if updated G = ID
\ signal no skip/dup
\ else signal skip
\ store current PID for next check
\ if TX message flag reset
\ convert keystroke to character
\ if it is a backspace from keyboard
\ and if keyboard byte counter > 0
\ trim right end of packet
\ back up byte counter
\ else if it is a Cr
\ add vbCrLf to TX packet
\ update AutoSend string
\ reset keyboard byte counter
\ set TX message flag
\ set next TX packet flag
\ show keyboard locked
\ else add byte to TX packet
\ increment byte counter
\ if keyboard byte counter is 238
\ add vbCrLf to TX message
\ update AutoSend string
\ place cursor at end
\ show key input and vbCrLf
\ block double key display
\ reset keyboard byte counter
\ set TX message flag
\ set next TX packet flag
\ show keyboard locked
\ manage textbox memory
\ block keystroke if TX flag set
\ if next TX packet flag set
\ if TPkt$ has new bytes
\ get number of bytes in TPkt$
\ for each byte in TPkt$
\ load byte in Temp$
\ if byte in Temp$ is a FEND$
\ add ESC$ & TFEND$ to TSPkt$
\ else if byte is an ESC$
\ add ESC$ & TESC$ to TSPkt$
\ else just add Temp$ byte to TSPkt$
\ add new message to TX FIFO
\ clear new message string
\ clear SLIP encoded string
\ skip 25% to allow other traffic
\ clear next TX packet flag
\ get number of bytes in TXPkt$
\ if less than 240 bytes
\ show number on TX progress bar
\ else cap TX progress bar at 240
\ if TXPkt$ holds bytes
\ and there are more than 24 bytes
\ put the first 24 bytes in SPkt$
\ and hold the rest in TXPkt$
\ else put all TXPkt$ bytes in SPkt$
\ and clear TXPkt$

```

```

        End If
        Call NxtPkt
        SPkt$ = FEND$ & PktHdr$ & Chr$(P) & SPkt$ & FEND$
        MSCComml.Output = SPkt$
        TFlag = 1
        ANFlag = 1
        TCnt = 0
        XCnt = 0
    Else
        TXFlag = 0
        StatusBar1.Panels(4).Text = "Keyboard Active"
    End If
End If
End If
End Sub

Public Sub Xfer()
    TCnt = TCnt + 1
    If TCnt > 4 Then
        If TFlag = 1 Then
            TCnt = 0
            XCnt = XCnt + 1
            If XCnt < 17 Then
                MSCComml.Output = SPkt$
                TCnt = 0
            Else
                Call ReSetTX
                Call LenTrap
                Text1.SelStart = Len(Text1.Text)
                Text1.SelText = " <xfer fault>" & vbCrLf
            End If
        End If
    End If
    If TCnt > 64 Then
        If ANFlag = 1 Then
            Call ReSetTX
            Call LenTrap
            Text1.SelStart = Len(Text1.Text)
            Text1.SelText = " <ACK/NAK fault>" & vbCrLf
        End If
    End If
End Sub

Public Sub ReSetTX()
    TFlag = 0
    TXFlag = 0
    TNFlag = 0
    ANFlag = 0
    NAFlag = 0
    TCnt = 0
    XCnt = 0
    TXPkt$ = ""
    SPkt$ = ""
    ProgressBar1.Value = 0
    StatusBar1.Panels(4).Text = "Keyboard Active"
End Sub

Public Sub ASPkt()
    If NAFlag = 0 Then
        Call GetPkt
        Temp$ = TPkt$
        Call LenTrap
        Text1.SelStart = Len(Text1.Text)
        Text1.SelText = Temp$
        TXFlag = 1
        TNFlag = 1
        StatusBar1.Panels(4).Text = "Keyboard Locked"
        Call SndPkt
        NAFlag = 1
    End If
End Sub

Public Sub GetPkt()
    TPkt$ = ASStr$
End Sub

Public Sub NxtPkt()
    P = P + 1

```

```

\ bump packet ID number
\ build packet
\ send packet
\ set transfer flag
\ set ACK/NAK flag
\ clear TX timeout counter
\ clear TX transfer retry counter
\ clear TX flag when all bytes sent
\ show keyboard active
\ increment TX timeout counter
\ if trying for more than 1 second
\ and transfer flag still set
\ reset TCnt
\ increment transfer retry counter
\ if XCnt not greater than 16
\ resend packet
\ reset TX timeout counter
\ else reset TX after eight tries
\ manage textbox memory
\ put cursor to end of text
\ show transfer fault message
\ if more than 16 seconds
\ and if ACK/NAK flag still set
\ reset TX
\ manage textbox memory
\ put cursor to end of text
\ show ACK/NAK fault message
\ reset transfer flag
\ reset TX message flag
\ reset next TX packet flag
\ reset ACK/NAK flag
\ reset next AutoSend flag
\ reset TCnt
\ reset XCnt
\ clear TX message string
\ clear send packet string
\ clear progress bar
\ show keyboard active
\ if next AutoSend flag reset
\ get next message packet(s)
\ use Temp$ for local display
\ manage textbox memory
\ put cursor at end of text
\ add text to textbox
\ set TX message flag
\ set next TX packet flag
\ show keyboard locked
\ send via SndPkt
\ set next AutoSend flag
\ message string for AutoSend
\ increment packet number

```

```

    If P = 8 Then                                ` if packet number greater than 7
        P = 0                                    ` reset to 0
    End If
End Sub

Public Sub LenTrap()
    If Len(Text1.Text) > 16000 Then              ` avoid textbox memory overflow
        Text1.Text = ""                         ` clear TX textbox
        Text1.SelStart = Len(Text1.Text)        ` put cursor at end of text
    End If
    If Len(Text2.Text) > 16000 Then              ` avoid textbox memory overflow
        Text2.Text = ""                         ` clear RX textbox
        Text2.SelStart = Len(Text2.Text)        ` put cursor at end of text
    End If
End Sub

Private Sub mnuExit_Click()
    MSComm1.PortOpen = False                    ` close com port
    End                                         ` done!
End Sub

Private Sub Form_Unload(Cancel As Integer)
    MSComm1.PortOpen = False                    ` close com port
    End                                         ` done!
End Sub

Private Sub mnuClear_Click()
    Text1.Text = ""                             ` clear TX textbox
    Text1.SelStart = Len(Text1.Text)            ` put cursor at end of text
    Text2.Text = ""                             ` clear RX textbox
    Text2.SelStart = Len(Text2.Text)            ` put cursor at end of text
End Sub

Private Sub mnuDups_Click()
    If DupFltr = 0 Then                          ` if show RX dups active
        DupFltr = 1                             ` toggle to inactive
        mnuDups.Checked = False                 ` and uncheck Show RX Dups
    Else
        DupFltr = 0                             ` else toggle active
        mnuDups.Checked = True                  ` and check Show RX Dups
    End If
End Sub

Private Sub mnuShw_Click()
    If ShwACK = 1 Then                          ` if show ACK/NAK active
        ShwACK = 0                             ` toggle to inactive
        mnuShw.Checked = False                 ` and uncheck Show ACK/NAK
    Else
        ShwACK = 1                             ` else toggle active
        mnuShw.Checked = True                  ` and check Show ACK/NAK
    End If
End Sub

Private Sub mnuAutoSnd_Click()
    ASFlag = ASFlag Xor 1                       ` toggle AutoSend flag
    If ASFlag = 0 Then                          ` if flag reset
        Call ReSetTX                            ` reset TX
        Text1.ForeColor = QBColor(15)          ` make letters white
        mnuAutoSnd.Checked = False            ` uncheck AutoSend
    End If
    If ASFlag = 1 Then                          ` if flag active
        PCnt = 0                                ` clear TX tries counter
        NAFlag = 0                              ` clear next AutoSend flag
        Text1.ForeColor = QBColor(10)         ` make letters green
        mnuAutoSnd.Checked = True            ` check AutoSend
    End If
End Sub

Private Sub mnuFN1_Click()
    FNnode = 1                                  ` from Node = 1
    Call BldHdr                                 ` build new packet header
    Call RstFrmChk                             ` reset all From check marks
    mnuFN1.Checked = True                       ` check Node 1
End Sub

Private Sub mnuFN2_Click()
    FNnode = 2                                  ` from Node = 2
    Call BldHdr                                 ` build new packet header
    Call RstFrmChk                             ` reset all From check marks
    mnuFN2.Checked = True                       ` check Node 2
End Sub

```

```

Private Sub mnuFN3_Click()
    FNode = 3
    Call BldHdr
    Call RstFrmChk
    mnuFN3.Checked = True
End Sub
Private Sub mnuFN4_Click()
    FNode = 4
    Call BldHdr
    Call RstFrmChk
    mnuFN4.Checked = True
End Sub
Public Sub RstFrmChk()
    mnuFN1.Checked = False
    mnuFN2.Checked = False
    mnuFN3.Checked = False
    mnuFN4.Checked = False
End Sub
Private Sub mnuTN1_Click()
    TNode = 1
    Call BldHdr
    Call RstToChk
    mnuTN1.Checked = True
End Sub
Private Sub mnuTN2_Click()
    TNode = 2
    Call BldHdr
    Call RstToChk
    mnuTN2.Checked = True
End Sub
Private Sub mnuTN3_Click()
    TNode = 3
    Call BldHdr
    Call RstToChk
    mnuTN3.Checked = True
End Sub
Private Sub mnuTN4_Click()
    TNode = 4
    Call BldHdr
    Call RstToChk
    mnuTN4.Checked = True
End Sub
Public Sub RstToChk()
    mnuTN1.Checked = False
    mnuTN2.Checked = False
    mnuTN3.Checked = False
    mnuTN4.Checked = False
End Sub
Public Sub BldHdr()
    TF = (16 * TNode) + FNode
    PktHdr$ = Chr$(TF)
End Sub

```

\ from Node = 3
 \ build new packet header
 \ reset all From check marks
 \ check Node 3

\ from Node = 4
 \ build new packet header
 \ reset all From check marks
 \ check Node 4

\ uncheck From Node 1
 \ uncheck From Node 2
 \ uncheck From Node 3
 \ uncheck From Node 4

\ To Node = 1
 \ build new packet header
 \ reset all To check marks
 \ check Node 1

\ To Node = 2
 \ build new packet header
 \ reset all To check marks
 \ check Node 2

\ To Node = 3
 \ build new packet header
 \ reset all To check marks
 \ check Node 3

\ To Node = 4
 \ build new packet header
 \ reset all To check marks
 \ check Node 4

\ uncheck To Node 1
 \ uncheck To Node 2
 \ uncheck To Node 3
 \ uncheck To Node 4

\ TF is numeric To/From node address
 \ Chr\$(TF) is To/From packet header

5.3 DK110K.ASM

```

; DK110K.ASM 2002.08.01 @ 20:00 CDT
; See RFM Virtual Wire(r) Development Kit Warranty & License for terms of use
; Experimental software - NO representation is
; made that this software is suitable for any purpose
; Copyright(c) 2000 - 2002, RF Monolithics, Inc.
; AT89C2051 assembler source code file (TASM 3.01 assembler)
; Low signal-to-noise protocol for RFM ASH transceiver
; Integrate & dump PLL (I&D) - 62.40 us tick

.NOLIST
#INCLUDE "8051.H" ; tasm 8051 include file
.LIST

```

```

; constants:

ITMOD      .EQU    022H      ; set timers 0 and 1 to mode 2
ITICK      .EQU    141      ; set timer T0 for 62.40 us tick
ISMOD      .EQU    080H      ; SMOD = 1 in PCON

IBAUD      .EQU    0FAH      ; 19.2 kbps @ 22.1184 MHz, SMOD = 1
ISCON      .EQU    050H      ; UART mode 1

RMPT       .EQU    159      ; PLL ramp top value (modulo 0 to 159)
RMPW       .EQU    159      ; PLL ramp reset (wrap) value
RMP5       .EQU    80       ; PLL ramp switch value
RMPINC     .EQU    20       ; PLL ramp increment value
RMP5ADV    .EQU    29       ; PLL 5% advance increment value (20 + 9)
RMP5RET    .EQU    11       ; PLL 5% retard increment value (20 - 9)

TXMB       .EQU    044H      ; TX message buffer start address
RXMB       .EQU    062H      ; RX message buffer start address
FEND       .EQU    0C0H      ; FEND framing character (192)
SOPL       .EQU    08AH      ; SOP low correlator pattern
SOPH       .EQU    0B3H      ; SOP high correlator pattern
TXRO       .EQU    020H      ; TX retry timer count

FCSS       .EQU    0FFH      ; FCS seed
FCSH       .EQU    084H      ; FCS high XOR mask
FCSL       .EQU    08H       ; FCS low XOR mask
FCVH       .EQU    0F0H      ; FCS valid high byte pattern
FCVL       .EQU    0B8H      ; FCS valid low byte pattern

; stack: 08H - 021H (26 bytes)

; bit labels:

WBFLG      .EQU    010H      ; warm boot flag (future use)
PLLON      .EQU    011H      ; RX PLL control flag
RXISM      .EQU    012H      ; RX inverted input sample
RXSMP      .EQU    013H      ; RX input sample
LRXSM      .EQU    014H      ; last RX input sample
RXBIT      .EQU    015H      ; RX input bit
RXBFLG     .EQU    016H      ; RX input bit flag
SOPFLG     .EQU    017H      ; SOP detect flag
RXSFLG     .EQU    018H      ; RX symbol flag
RM         .EQU    019H      ; RX FCS message bit
OKFLG      .EQU    01AH      ; RX FCS OK flag

SIFLG      .EQU    01BH      ; serial in active flag
TSFLG      .EQU    01CH      ; output TX sample flag
TXSMP      .EQU    01DH      ; TX output sample
TXBIT      .EQU    01EH      ; TX message bit
TM         .EQU    01FH      ; TX FCS message bit
TXFLG      .EQU    020H      ; TX active flag
TMFLG      .EQU    021H      ; TX message flag
TOFLG      .EQU    022H      ; get message time out flag
AMFLG      .EQU    023H      ; AutoSend message flag
ASFLG      .EQU    024H      ; AutoSend active flag

SFLG0      .EQU    025H      ; spare flag 0
SFLG1      .EQU    026H      ; spare flag 1
SFLG2      .EQU    027H      ; spare flag 2
SFLG3      .EQU    028H      ; spare flag 3
SFLG4      .EQU    029H      ; spare flag 4
SFLG5      .EQU    02AH      ; spare flag 5
SFLG6      .EQU    02BH      ; spare flag 6
SFLG7      .EQU    02CH      ; spare flag 7
SFLG8      .EQU    02DH      ; spare flag 8
SFLG9      .EQU    02EH      ; spare flag 9
SFLGA      .EQU    02FH      ; spare flag A

; register usage:

; R0       RX data pointer
; R1       TX data pointer
; R2       PLL ramp buffer
; R3       RX FCS buffer A
; R4       not used
; R5       TX FCS buffer A
; R6       TX FCS buffer B
; R7       RX FCS buffer B

```

```

; byte labels:

BOOT      .EQU      022H      ; 1st byte of flags

RXID      .EQU      026H      ; RX integrate & dump buffer
RXBL      .EQU      027H      ; RX low buffer, SOP correlator etc.
RXBH      .EQU      028H      ; RX high buffer, SOP correlator etc.
RXBB      .EQU      029H      ; RX symbol decode byte buffer
RMDC      .EQU      02AH      ; RX symbol decode loop counter
RMBIC     .EQU      02BH      ; RX symbol decode index pointer
RMBYC     .EQU      02CH      ; RX message byte counter
RMFCS     .EQU      02DH      ; RX FCS byte buffer
RMSBC     .EQU      02EH      ; RX symbol bit counter
RMLPC     .EQU      02FH      ; RX message loop counter
RMFCC     .EQU      030H      ; RX message FCS counter, etc.

TMFCC     .EQU      031H      ; TX timer & loop counter
TXSMC     .EQU      032H      ; TX output sample counter
TMBIC     .EQU      033H      ; TX message bit counter
TMBYT     .EQU      034H      ; TX message byte buffer
TMBYC     .EQU      035H      ; TX message byte counter
TXSL      .EQU      036H      ; TX message symbol low buffer
TXSH      .EQU      037H      ; TX message symbol high buffer
TMFCS     .EQU      038H      ; TX FCS byte buffer
TXTL      .EQU      039H      ; TX timer low byte
TXTH      .EQU      03AH      ; TX timer high byte

BUF0      .EQU      03BH      ; spare buffer 0
BUF1      .EQU      03CH      ; spare buffer 1
BUF2      .EQU      03DH      ; spare buffer 2
BUF3      .EQU      03EH      ; spare buffer 3
BUF4      .EQU      03FH      ; spare buffer 4
BUF5      .EQU      040H      ; spare buffer 5
BUF6      .EQU      041H      ; spare buffer 6
BUF7      .EQU      042H      ; spare buffer 7
BUF8      .EQU      043H      ; spare buffer 8

; I/O pins:

MAX       .EQU      P1.6      ; Maxim 218 power (on = 1)

RXPIN     .EQU      P3.2      ; RX input pin (inverted data)
TXPIN     .EQU      P3.3      ; TX output pin (on = 1)
PTT       .EQU      P1.7      ; transmit enable (TX = 0)

PCRCV     .EQU      P3.7      ; PC (host) input LED (on = 0)
RFRCV     .EQU      P3.5      ; RX FCS OK LED (on = 0)
RXI       .EQU      P3.4      ; RX activity LED (on = 0)

ID0       .EQU      P1.2      ; jumper input bit 0 (dot end)
ID1       .EQU      P1.3      ; jumper input bit 1
ID2       .EQU      P1.4      ; jumper input bit 2
ID3       .EQU      P1.5      ; jumper input bit 3

; start of code:

          .ORG      00H      ; hardware reset
reset:    SETB      WBFLG     ; set warm boot flag
          AJMP     start     ; jump to start

t_isr:    .ORG      0BH      ; timer 0 interrupt vector
          ACALL   tick       ; sampling tick subroutine
          RETI      ; interrupt done

s_isr:    .ORG      023H     ; serial interrupt vector
          ACALL   srio       ; serial I/O subroutine
          CLR     TI         ; clear TI (byte sent) flag
          CLR     RI         ; clear RI (byte received) flag
          RETI      ; interrupt done

start:    .ORG      040H     ; above interrupt code space
          ACALL   setup     ; initialization code

main:     JNB     AMFLG,mn0   ; skip if AutoSend idle
          CLR     PCRCV      ; else turn PCRCV LED on
          ACALL   do_as      ; do AutoSend
          SETB    PCRCV      ; turn PCRCV LED off
mn0:     ACALL   rxsop       ; do RX SOP detect
          JNB    SOPFLG,main ; if not SOP loop to main
          ACALL   do_rx      ; else do RX message

```

```

mn_d:    AJMP     main          ; and loop to main

do_rx:   CLR      ES           ; deactivate serial interrupts
         ACALL   rxmsg        ; decode RX message
         CLR     PLLON        ; idle RX PLL
         ACALL   rxfcs        ; test RX message FCS
         JNB    OKFLG,rx0     ; reset if FCS error
         ACALL   rxsnd        ; else send RX message to host
rx0:     ACALL   rxrst        ; reset for next RX message
         SETB   PLLON        ; enable RX PLL
         CLR    TI           ; clear TI flag
         CLR    RI           ; clear RI flag
         SETB   ES           ; activate serial interrupts
rx_d:    RET                  ; RX done

tick:    PUSH    PSW          ; push status
         PUSH    ACC          ; push accumulator
         MOV     C,RXPIN      ; read RX input pin
         MOV     RXISM,C      ; store as inverted RX sample
         JNB    TSFLG,tic0    ; skip if TX sample out idle
         MOV     A,TXSMC      ; else get sample count
         JZ     tic0          ; skip if 0
         MOV     C,TXBIT      ; else load TX bit
         MOV     TXPIN,C      ; into TX output pin
         DEC    TXSMC        ; decrement sample count
tic0:    JNB    PLLON,tic1    ; skip if PLL idle
         ACALL   pll          ; else run RX PLL
tic1:    JNB    TOFLG,tic2    ; skip if get message timeout idle
         INC    TMFCC         ; else bump timeout counter
         MOV     A,TMFCC      ; get counter
         CJNE   A,#50,tic2    ; skip if counter <> 50 (5.2 ms)
         CLR    TOFLG        ; else reset time out flag
         MOV     TMFCC,#0     ; reset counter
tic2:    JNB    ASFLG,tick_d   ; done if AutoSend idle
         INC    TXTL         ; else bump TX timer low
         MOV     A,TXTL       ; load TX timer low
         JNZ    tick_d        ; done if no rollover
         INC    TXTH         ; else bump TX timer high
         MOV     A,TXTH       ; load timer
         CLR    C            ; clear borrow
         SUBB   A,#TXRO      ; subtract TX retry count
         JNZ    tick_d        ; if <> 0 done for now
         SETB   AMFLG        ; else set AM message flag
         CLR    A            ; clear A
         MOV    TXTL,A        ; clear TX timer low
         MOV    TXTH,A        ; clear TX timer high
tick_d:  POP     ACC          ; pop accumulator
         POP    PSW          ; pop status
         RET                  ; tick done

pll:     MOV     C,RXSMP      ; load RX sample
         MOV     LRXSM,C      ; into last RX sample
         MOV     C,RXISM      ; get inverted RX sample
         CPL    C            ; invert
         MOV     RXSMP,C      ; and store
         JNC    pll0          ; if <> 1 jump to pll0
         INC    RXID         ; else increment I&D
pll0:    JNB    LRXSM,pll1    ; if last sample 1
         CPL    C            ; invert current sample
pll1:    JNC    pll4          ; if no edge jump to pll4
         MOV     A,R2         ; else get PLL value
         CLR    C            ; clear borrow
         SUBB   A,#RMPS      ; subtract ramp switch value
         JC     pll3          ; if < 0 then retard PLL
pll2:    MOV     A,R2         ; else get PLL value
         ADD    A,#RMPA      ; add (RMPI + 5%)
         MOV     R2,A         ; store PLL value
         AJMP   pll5          ; and jump to pll5
pll3:    MOV     A,R2         ; get PLL value
         ADD    A,#RMPR      ; add (RMPI - 5%)
         MOV     R2,A         ; store PLL value
         AJMP   pll5          ; and jump to pll5
pll4:    MOV     A,R2         ; get PLL value
         ADD    A,#RMPI      ; add ramp increment
         MOV     R2,A         ; store new PLL value
pll5:    CLR    C            ; clear borrow
         MOV    A,R2         ; get PLL ramp value
         SUBB   A,#RMPT      ; subtract ramp top
         JC     pllD          ; if < 0 don't wrap
pll6:    MOV     A,R2         ; else get PLL value
         CLR    C            ; clear borrow

```

```

SUBB    A,#RMPW      ; subtract reset value
MOV     R2,A         ; and store result
CLR     C            ; clear borrow
MOV     A,RXID       ; get I&D buffer
SUBB    A,#5         ; subtract 5
JNC     pll7         ; if I&D count => 5 jump to pll7
CLR     RXBIT        ; else RX bit = 0 for I&D count < 5
SETB    RXBFLG       ; set new RX bit flag
MOV     RXID,#0      ; clear the I&D buffer
AJMP    pll8         ; and jump to pll8
pll7:   SETB    RXBIT        ; RX bit = 1 for I&D count => 5
        SETB    RXBFLG       ; set new RX bit flag
pll8:   MOV     RXID,#0      ; clear the I&D buffer
        JB      SOPFLG,pllA    ; skip after SOP detect
        MOV     A,RXBH       ; else get RXBH
        CLR     C            ; clear carry
        RRC     A            ; rotate right
        JNB    RXBIT,pll9    ; if bit = 0 jump to pll9
        SETB    ACC.7        ; else set 7th bit
pll9:   MOV     RXBH,A       ; store RXBH
        MOV     A,RXBL       ; get RXBL
        RRC     A            ; shift and pull in carry
        MOV     RXBL,A       ; store RXBL
        AJMP    pll_d        ; done for now
pllA:   MOV     A,RXBL       ; get RXBL
        CLR     C            ; clear carry
        RRC     A            ; shift right
        JNB    RXBIT,pllB    ; if bit = 0 jump to pllB
        SETB    ACC.5        ; else set 5th bit
pllB:   MOV     RXBL,A       ; store RXBL
        INC     RMSBC        ; bump bit counter
        MOV     A,RMSBC      ; get counter
        CJNE   A,#6,pllC    ; if <> 6 jump to pllC
        MOV     RXBB,RXBL    ; else get symbol
        MOV     RMSBC,#0     ; reset counter
        SETB    RXSFLG      ; set symbol flag
pllC:   AJMP    pll_d        ; done
pllD:   CLR     RXBFLG       ; clear RXBFLG
pll_d:  RET              ; PLL done

rxsop:  JNB    RXBFLG,sop_d  ; done if no RX bit flag
        CLR     RXBFLG       ; else clear RX bit flag
        MOV     A,RXBL       ; get low RX buffer
        CJNE   A,#SOPL,sop_d ; done if <> SOPL
        MOV     A,RXBH       ; else get high RX buffer
        CJNE   A,#SOPH,sop_d ; done if <> SOPH
        CLR     A            ; else clear A
        MOV     RXBL,A       ; clear RX low buffer
        MOV     RXBH,A       ; clear RX high buffer
        MOV     RMSBC,A      ; clear RX symbol bit counter
        CLR     RXSFLG      ; clear RX symbol flag
        SETB    SOPFLG      ; set SOP detected flag
        CLR     RXI         ; RXI LED on
sop_d:  RET              ; SOP detect done

rxmsg:  JNB    RXSFLG,rxmsg  ; wait for RX symbol flag
        CLR     RXSFLG       ; clear RX symbol flag
rxm1:   MOV     DPTR,#smb1    ; point to RX symbol decode table
        MOV     RMDC,#16     ; 16 symbol decode table entries
        MOV     RMBIC,#0     ; index into symbol table
rxm2:   MOV     A,RMBIC      ; load index into A
        MOVC   A,@A+DPTR    ; get table entry
        XRL    A,RXBB       ; XOR to compare with RXBB
        JZ     rxm3         ; exit loop with decoded nibble
        INC     RMBIC        ; else bump index
        DJNZ   RMDC,rxm2    ; and try to decode again
rxm3:   MOV     A,RMBIC      ; get decoded nibble
        SWAP   A            ; swap to high nibble
        MOV     RXBH,A       ; into RXBH (low nibble is high)
rxm4:   JNB    RXSFLG,rxm4   ; wait for symbol flag
        CLR     RXSFLG       ; clear flag
rxm5:   MOV     DPTR,#smb1    ; point to symbol decode table
        MOV     RMDC,#16     ; 16 symbol decode table entries
        MOV     RMBIC,#0     ; reset symbol table index
rxm6:   MOV     A,RMBIC      ; load index into A
        MOVC   A,@A+DPTR    ; get table entry
        XRL    A,RXBB       ; XOR to compare with RXBB
        JZ     rxm7         ; exit loop with decoded nibble
        INC     RMBIC        ; else bump index
        DJNZ   RMDC,rxm6    ; and try to decode again
rxm7:   MOV     A,RMBIC      ; get decoded nibble

```

```

ORL      A,RXBH      ; add RXBH low
SWAP    A            ; nibbles now in right order
MOV     RXBH,A       ; store in RXBH
MOV     @R0,RXBH     ; and store in RX message buffer
CJNE   R0,#RXMB,rxm8 ; skip if not 1st message byte
MOV     A,RXBH       ; else get 1st byte
ANL     A,#63        ; mask upper 2 bits
MOV     RMBYC,A      ; load message byte counter
MOV     RMFCC,A      ; and RX message loop counter
CLR     C            ; clear borrow
SUBB   A,#28        ; compare # bytes to 28
JC     rxm8          ; skip if < 28
MOV     RMBYC,#4     ; else force byte counter to 4
MOV     RMFCC,#4     ; and force loop counter to 4
rxm8:   INC          R0 ; bump pointer
DJNZ   RMFCC,rxmsg  ; if <> 0 get another byte
MOV     R0,#RXMB    ; reset RX message pointer
SETB   RXI          ; turn LED off
rxm_d:  RET          ; RX message done

rxfcs:  MOV          RMFCC,RMBYC ; move byte count to loop counter
rxf0:   MOV          RMFCS,@R0  ; get next message byte
INC     R0           ; bump pointer
ACALL  b_rfcs       ; build FCS
DJNZ   RMFCC,rxf0  ; loop for next byte
ACALL  a_rfcs       ; test FCS
rxf_d:  RET          ; RX FCS done
rxsnd:  CLR          PCRCV      ; turn PC LED on
DEC     RMBYC       ; don't send
DEC     RMBYC       ; the 2 FCS bytes
MOV     R0,#RXMB    ; reset RX message pointer
MOV     @R0,#FEND   ; replace # bytes with 1st FEND
CLR     TI          ; clear TI flag
rxs1:   MOV          SBUF,@R0   ; send byte
rxs2:   JNB         TI,rxs2     ; wait until byte sent
CLR     TI          ; clear TI flag
INC     R0           ; bump pointer
DJNZ   RMBYC,rxs1  ; loop to echo message
MOV     SBUF,#FEND  ; add 2nd FEND
rxs3:   JNB         TI,rxs3     ; wait until byte sent
CLR     TI          ; clear TI flag
SETB   RFRCV       ; turn FCS LED off
SETB   PCRCV       ; turn PC LED off
rxs_d:  RET          ; send RX message done

rxrst:  CLR          A          ; clear A
MOV     RXBH,A      ; clear buffer
MOV     RXBL,A      ; clear buffer
MOV     RXBB,A      ; clear buffer
MOV     RMBYC,A     ; clear rx byte count
MOV     RMFCC,A     ; clear loop counter
MOV     R0,#RXMB    ; point R0 to message start
CLR     OKFLG       ; clear packet OK flag
CLR     SOPFLG      ; enable SOP test
SETB   RXI         ; RXI LED off
rxr_d:  RET          ; RX reset done

b_rfcs: MOV          RMLPC,#8    ; load loop count of 8
brf0:   CLR          C          ; clear carry bit
MOV     A,RMFCS     ; load RX message byte
RRC     A           ; shift lsb into carry
MOV     RMFCS,A     ; store shifted message byte
MOV     RM,C        ; load RM with lsb
CLR     C           ; clear carry bit
MOV     A,R3        ; load high FCS byte
RRC     A           ; shift right
MOV     R3,A        ; store shifted high FCS
MOV     A,R7        ; load low FCS byte
RRC     A           ; shift and pull in bit for FCS high
MOV     R7,A        ; store shifted low FCS
JNB    RM,brf1     ; if lsb of low FCS = 0, jump to brf1
CPL    C           ; else complement carry bit
brf1:   JNC         brf2       ; if RM XOR (low FCS lsb) = 0 jump to brf2
MOV     A,R3        ; else load high FCS
XRL    A,#FCSH     ; and XOR with high FCS poly
MOV     R3,A        ; store high FCS
MOV     A,R7        ; load low FCS
XRL    A,#FCSL     ; XOR with low FCS poly
MOV     R7,A        ; store low FCS
brf2:   DJNZ       RMLPC,brf0  ; loop through bits in message byte
brfcs_d: RET        ; done this pass

```

```

a_rfcs:  MOV    A,R3          ; load FCS high
        XRL    A,#FCVH      ; compare with 0F0H
        JNZ    arf0         ; if <> 0 jump to arf0
        MOV    A,R7          ; load FCS low
        XRL    A,#FCVL      ; else compare with 0B8H
        JNZ    arf0         ; if <> 0 jump to arf0
        CLR    RFRCV        ; else turn FCS LED on
        SETB   OKFLG        ; set FCS OK flag
arf0:    MOV    R3,#FCSS     ; reseed FCS high
        MOV    R7,#FCSS     ; reseed FCS low
arfcs_d: RET                ; RX FCS done

srio:    PUSH   PSW          ; save
        PUSH   ACC          ; environment
        JNB   TI,sr_0       ; skip if TI flag clear
        CLR   TI            ; else clear TI flag
sr_0:    JNB   RI,sr_1       ; skip if RI flag clear
        CLR   RI            ; else clear RI flag
        JNB   SIFLG,sr_1    ; skip if serial in flag reset
        CLR   PCRCV        ; else turn PC LED on
        ACALL do_tx         ; get & TX host message
        SETB  PCRCV        ; turn PC LED off
sr_1:    POP    ACC          ; restore
        POP    PSW          ; environment
        RET                ; serial in done

do_as:   CLR    PLLON       ; idle RX PLL
        ACALL hello2       ; get AutoSend message
        ACALL txfcs        ; build and add FCS
        ACALL txpre        ; send TX preamble
        ACALL txmsg        ; send TX message
        ACALL txrst        ; reset TX
        SETB  PLLON       ; enable RX PLL
        RET                ; TX message done

do_tx:   ACALL txget        ; get TX message from host
        JNB   TXFLG,do0    ; skip if TXFLG not set
        CLR   PLLON       ; else idle RX PLL
        ACALL txfcs        ; build and add FCS
        ACALL txpre        ; send TX preamble
        ACALL txmsg        ; send TX message
do0:     ACALL txrst        ; reset TX
        SETB  PLLON       ; enable RX PLL
        RET                ; TX message done

txget:   MOV    A,SBUF       ; get byte
        MOV    TMBYT,A      ; copy to TMBYT
        XRL    A,#FEND      ; compare to FEND
        JZ    txg0         ; if FEND jump to txg0
        AJMP  txg_d         ; else done
txg0:    MOV    @R1,TMBYT    ; store 1st FEND
        INC   TMBYC        ; bump TX byte counter
txg1:    MOV    TMFCC,#0     ; reset timeout counter
        SETB  TOFLG        ; set timeout flag
        CLR   RI            ; reset flag
txg2:    JNB   TOFLG,txg3   ; if TOFLG reset jump to txg3
        JNB   RI,txg2      ; else loop until next byte
        CLR   RI            ; reset RI flag
        CLR   TOFLG        ; reset TOFLG
        AJMP  txg4         ; and jump to txg4
txg3:    MOV    TMBYC,#2     ; look like null message
        AJMP  txg6         ; and jump to txg6
txg4:    MOV    A,SBUF       ; get byte
        MOV    TMBYT,A      ; copy to TMBYT
        INC   TMBYC        ; bump byte counter
        INC   R1            ; bump pointer R1
        MOV   @R1,TMBYT    ; store byte
        MOV   A,TMBYC      ; load counter
        CLR   C             ; clear carry
        SUBB  A,#26        ; test for 26 bytes
        JZ    txg5         ; if 26 handle overflow at txg5
        MOV   A,TMBYT      ; else load byte
        CJNE  A,#FEND,txg1 ; if <> FEND loop to txg1
        AJMP  txg6         ; else jump to txg6 on 2nd FEND
txg5:    MOV    @R1,#FEND    ; force 2nd FEND
txg6:    MOV    R1,#TXMB     ; reset TX message pointer
        MOV   A,TMBYC      ; get byte count
        CJNE  A,#2,txg7    ; if <> 2 jump to txg7
        MOV   TMBYC,#0     ; else reset byte counter
        AJMP  txg_d         ; jump to txg_d

```

```

txg7:   CLR      SIFLG      ; idle serial in
        SETB    TXFLG      ; set TX flag
txg_d:  RET                               ; get TX message done

txfcs:  INC      TMBYC      ; # bytes including FCS
        MOV     @R1,TMBYC   ; replace 1st FEND with # bytes
        MOV     TMFCC,TMBYC ; move byte count to loop counter
        DEC     TMFCC      ; loop count is 2 less
        DEC     TMFCC      ; than # bytes including FCS
txf0:   MOV     TMFCS,@R1   ; get next message byte
        INC     R1         ; bump pointer
        ACALL  b tfcs      ; build FCS
        DJNZ   TMFCC,txf0  ; loop for next byte
        ACALL  a tfcs      ; add FCS
        MOV     R1,#TXMB   ; reset TX message pointer
        SETB   TMFLG      ; set TX message flag
txf_d:  RET                               ; TX FCS done

txpre:  CLR      PTT        ; turn PTT on
        MOV     B,#200     ; load PTT delay count
txp0:   DJNZ   B,txp0      ; loop to delay
txp1:   MOV     DPTR,#tstrt ; point to TX start table
        MOV     B,#0       ; clear B
        MOV     A,B        ; B holds table offset
        MOVC   A,@A+DPTR   ; load table entry
        MOV     TMBYT,A    ; into TMBYT
        MOV     TMBIC,#4   ; load bit count
        MOV     TXSMC,#0   ; clear sample count
txp2:   SETB   TSFLG      ; turn TX sample out on
        MOV     A,TXSMC    ; get sample count
        JNZ    txp2        ; loop until sample count 0
        MOV     A,TMBIC    ; get bit count
        JNZ    txp3        ; if <> 0 jump to txp3
        MOV     A,B        ; else get current offset (0 to 11)
        CLR     C          ; clear carry
        SUBB   A,#11      ; subtract ending offset
        JZ     txp_d       ; if 0 done
        INC    B          ; else bump byte count
        MOV    A,B        ; get count/offset
        MOVC   A,@A+DPTR   ; load table entry
        MOV    TMBYT,A    ; into TMBYT
        MOV    TMBIC,#4   ; reload bit count
txp3:   MOV    A,TMBYT    ; get TX message byte
        CLR    C          ; clear carry
        RRC    A          ; shift right into carry
        MOV    TXBIT,C    ; load next bit
        MOV    TMBYT,A    ; store shifted message byte
        DEC    TMBIC      ; decrement bit count
        MOV    TXSMC,#8   ; reload sample count
txp_d:  AJMP   txp2        ; loop again
        RET                               ; TX preamble done

txmsg:  MOV     B,#1        ; count 1st byte sent
        MOV    R1,#TXMB   ; reset TX message pointer
        MOV    A,@R1     ; get 1st TX message byte
        MOV    TMBYT,A    ; into TMBYT
        MOV    DPTR,#smb1 ; point to symbol table
        ANL   A,#0FH      ; clean offset
        MOVC  A,@A+DPTR   ; get 6-bit symbol
        MOV   TXSL,A      ; move to TXSL
        MOV   A,TMBYT     ; get TMBYT
        SWAP  A           ; swap nibbles
        ANL  A,#0FH      ; clean offset
        MOVC  A,@A+DPTR   ; get 6-bit symbol
        MOV   TXSH,A      ; move to TXSH
        MOV   TMBIC,#12   ; set bit count to 12
        MOV   TXSMC,#0   ; clear sample count
txm0:   MOV    A,TXSMC    ; get sample count
        JNZ  txm0        ; loop until sample count 0
        MOV   A,TMBIC    ; get bit count
        CLR   C          ; clear carry
        SUBB  A,#7        ; subtract 7
        JNC  txm1        ; if => 7 jump to txm1
        MOV   A,TMBIC    ; else get bit count
        JNZ  txm2        ; if > 0 jump to txm2
        MOV   A,B        ; else get current byte number
        CLR   C          ; clear carry
        SUBB  A,TMBYC     ; subtract TX message byte count
        JZ   txm3        ; if 0 done
        INC  R1          ; else bump byte pointer
        INC  B           ; and bump byte counter

```

```

MOV      A,@R1      ; get next byte
MOV      TMBYT,A    ; into TMBYT
MOV      DPTR,#smb1 ; point to symbol table
ANL      A,#0FH     ; offset
MOVC    A,@A+DPTR  ; get 6-bit symbol
MOV      TXSL,A     ; move to TXSL
MOV      A,TMBYT    ; get TMBYT
SWAP    A           ; swap nibbles
MOV      DPTR,#smb1 ; point to symbol table
ANL      A,#0FH     ; clean offset
MOVC    A,@A+DPTR  ; get 6-bit symbol
MOV      TXSH,A     ; move to TXSH
MOV      TMBIC,#12  ; set bit count to 12
txm1:   MOV      A,TXSL ; get low TX symbol
        CLR      C     ; clear carry
        RRC      A     ; shift right into carry
        MOV      TXBIT,C ; load next bit
        MOV      TXSL,A ; store shifted message byte
        DEC      TMBIC ; decrement bit count
        MOV      TXSMC,#8 ; reload sample count
        AJMP     txm0   ; loop again
txm2:   MOV      A,TXSH ; get high TX symbol
        CLR      C     ; clear carry
        RRC      A     ; shift right into carry
        MOV      TXBIT,C ; load next bit
        MOV      TXSH,A ; store shifted message byte
        DEC      TMBIC ; decrement bit count
        MOV      TXSMC,#8 ; reload sample count
        AJMP     txm0   ; loop again
txm3:   CLR      TSFLG ; clear TX sample out flag
        CLR      TXPIN ; clear TX out pin
txm_d:  SETB     PTT    ; turn PTT off
        RET          ; TX message done

txrst:  CLR      TMFLG ; clear TX message flag
        CLR      AMFLG ; clear AutoSend message flag
        CLR      A     ; reset for next TX
        MOV      TMBYT,A ; clear TX message byte
        MOV      TMFCC,A ; clear TX FCS count
        MOV      TXSMC,A ; clear TX out count
        MOV      TXSL,A ; clear TX symbol low
        MOV      TXSH,A ; clear TX symbol high
        MOV      R1,#TXMB ; point R1 to message start
        JB      ASFLG,txr_d ; skip if in AutoSend
        MOV      TMBYC,A ; clear TX message byte count
        CLR      TXFLG ; clear TX flag
        SETB     SIFLG ; set serial in flag active
txr_d:  RET          ; TX reset done

b_tfcs: MOV      B,#8   ; load loop count of 8
btf0:  CLR      C     ; clear carry bit
        MOV      A,TMFCS ; load TX message byte
        RRC      A     ; shift lsb into carry
        MOV      TMFCS,A ; store shifted message byte
        MOV      TM,C   ; load TM with lsb
        CLR      C     ; clear carry bit
        MOV      A,R5   ; load high FCS byte
        RRC      A     ; shift right
        MOV      R5,A   ; store shifted high FCS
        MOV      A,R6   ; load low FCS byte
        RRC      A     ; shift and pull in bit for FCS high
        MOV      R6,A   ; store shifted low FCS
        JNB     TM,btfl ; if lsb of low FCS = 0, jump to btfl
        CPL      C     ; else complement carry bit
btfl:  JNC      btff2   ; if TM XOR (low FCS lsb) = 0 jump to btff2
        MOV      A,R5   ; else load high FCS
        XRL     A,#FCSH ; and XOR with high FCS poly
        MOV      R5,A   ; store high FCS
        MOV      A,R6   ; load low FCS
        XRL     A,#FCSL ; XOR with low FCS poly
        MOV      R6,A   ; store low FCS
btff2: DJNZ    B,btff0 ; loop through bits in message byte
btfcs_d: RET          ; done this pass

a_tfcs: MOV      A,R6   ; load FCS (high/low switch)
        CPL      A     ; 1's complement
        MOV      @R1,A ; store at end of TX message
        INC      R1    ; increment TX message byte pointer
        MOV      A,R5   ; load FCS (high/low switch)
        CPL      A     ; 1's complement
        MOV      @R1,A ; store at end of TX message

```

```

MOV      R5,#FCSS      ; reseed FCS high
MOV      R6,#FCSS      ; reseed FCS low
atfcs_d: RET           ; add TX FCS done

setup:   CLR          EA          ; disable interrupts
         SETB        PTT         ; turn PTT off
         CLR          TXPIN       ; turn TX modulation off

tick_su: MOV          TMOD,#ITMOD ; set timers T0 and T1 to mode 2
         CLR          TR0         ; stop timer T0
         CLR          TFO         ; clear T0 overflow
         MOV          TH0,#ITICK  ; load count for 62.40 us tick
         MOV          TLO,#ITICK  ; load count for 62.40 us tick
         SETB        TR0         ; start timer T0
         SETB        ETO         ; unmask T0 interrupt

uart_su: SETB        MAX         ; power up Maxim RS232 converter
         CLR          TR1         ; stop timer T1
         CLR          TF1         ; clear T1 overflow
         MOV          TH1,#IBAUD  ; load baud rate count
         MOV          TL1,#IBAUD  ; load baud rate count
         MOV          PCON,#ISMOD ; SMOD = 1 for baud rate @ 22.1184 MHz
         SETB        TR1         ; start baud rate timer T1
         MOV          SCON,#ISCON ; enable UART mode 1
         MOV          A,SBUF      ; clear out UART RX buffer
         CLR          A          ; clear A
         CLR          RI          ; clear get flag
         CLR          TI          ; clear TI flag
         ACALL       hello       ; send start up message
         ACALL       inintr      ; initialize TX & RX
         SETB        SIFLG       ; set serial in flag active
         MOV          C,ID0       ; read ID0
         JC          ser_on       ; skip if no ID0 jumper
         ACALL       hello2      ; else do AutoSend

ser_on:  SETB        ES          ; enable serial ISR
isr_on:  SETB        EA          ; enable interrupts
         SETB        PLLON       ; activate RX PLL
setup_d: RET           ; setup done

inintr:  ANL          BOOT,#1     ; warm boot (don't reset WBFLG)
         MOV          R0,#35     ; starting here
         MOV          B,#93      ; for 93 bytes
         CLR          A          ; clear A
clr_r:   MOV          @R0,A       ; clear RAM
         INC          R0         ; bump RAM pointer
         DJNZ        B,clr_r     ; loop again
         MOV          R0,#RXMB   ; load RX buffer pointer
         MOV          R1,#TXMB   ; load TX buffer pointer
         MOV          R2,A       ; clear R2
         MOV          R3,#FCSS   ; seed R3
         MOV          R5,#FCSS   ; seed R5
         MOV          R6,#FCSS   ; seed R6
         MOV          R7,#FCSS   ; seed R7
         CLR          SOPFLG     ; clear SOPFLG
         SETB        PTO        ; tick is 1st priority
ini_d:   RET           ; done

hello:   MOV          DPTR,#table ; point to table
         MOV          B,#12      ; load loop count in B
         MOV          R7,#0      ; R7 has 1st table entry
snd_h:   MOV          A,R7        ; move table offset into A
         MOVC        A,@A+DPTR  ; load table byte
         CLR          TI         ; reset TI flag
         MOV          SBUF,A     ; send byte
nxt_tx:  JNB         TI,nxt_tx   ; wait until sent
         INC          R7         ; bump index
         DJNZ        B,snd_h     ; loop to send message
hello_d: RET           ; done

hello2:  MOV          DPTR,#tbl_2 ; point to table 2
         MOV          R1,#TXMB   ; reset TX buffer pointer
         MOV          B,#8       ; loop count for 8 bytes
         MOV          TMBYC,#0   ; offset for 1st table entry
snd_h2:  MOV          A,TMBYC    ; move table offset into A
         MOVC        A,@A+DPTR  ; load table byte
         MOV          @R1,A     ; into TX buffer
         INC          TMBYC     ; increment TMBYC
         INC          R1         ; increment R1
         DJNZ        B,snd_h2   ; loop to load message
         MOV          R1,#TXMB   ; reset TX pointer
         CLR          SIFLG     ; reset serial input
         SETB        TXFLG     ; set TX flag

```

```

        SETB      ASFLG      ; set AutoSend flag
helo2_d  RET

; tables:

tstrt:   .BYTE    10        ; preamble/SOP table
        .BYTE    10        ; table data
        .BYTE    10        ; table data
        .BYTE    10        ; table data
        .BYTE    10        ; table data
        .BYTE    10        ; table data
        .BYTE    10        ; table data
        .BYTE    10        ; table data
        .BYTE    8         ; table data
        .BYTE    3         ; table data
        .BYTE    11        ; table data

smb1:    .BYTE    13        ; 4-to-6 bit table
        .BYTE    14        ; table data
        .BYTE    19        ; table data
        .BYTE    21        ; table data
        .BYTE    22        ; table data
        .BYTE    25        ; table data
        .BYTE    26        ; table data
        .BYTE    28        ; table data
        .BYTE    35        ; table data
        .BYTE    37        ; table data
        .BYTE    38        ; table data
        .BYTE    41        ; table data
        .BYTE    42        ; table data
        .BYTE    44        ; table data
        .BYTE    50        ; table data
        .BYTE    52        ; table data
        .BYTE    00        ; overflow

table:   .BYTE    192       ; start up message
        .BYTE    ` `       ; table data
        .BYTE    `D'       ; table data
        .BYTE    `K'       ; table data
        .BYTE    `I'       ; table data
        .BYTE    `l'       ; table data
        .BYTE    `O'       ; table data
        .BYTE    `K'       ; table data
        .BYTE    `:'       ; table data
        .BYTE    ` `       ; table data
        .BYTE    ` `       ; table data
        .BYTE    192       ; table data

tbl_2:   .BYTE    192       ; table data
        .BYTE    `H'       ; table data
        .BYTE    `e'       ; table data
        .BYTE    `l'       ; table data
        .BYTE    `l'       ; table data
        .BYTE    `o'       ; table data
        .BYTE    ` `       ; table data
        .BYTE    192       ; table data

.END                                           ; end of source code

```

5.4 V110T05B.FRM

```

VERSION 5.00
Object = "{648A5603-2C6E-101B-82B6-000000000014}#1.1#0"; "MSCOMM32.OCX"
Object = "{F9043C88-F6F2-101A-A3C9-08002B2F49FB}#1.2#0"; "COMDLG32.OCX"
Begin VB.Form Form1
    Caption = "V110T05B Terminal Program for DK110K Protocol"
    ClientHeight = 4335
    ClientLeft = 165
    ClientTop = 735
    ClientWidth = 6375
    BeginProperty Font
        Name = "MS Sans Serif"
        Size = 9.75
        Charset = 0
        Weight = 400
        Underline = 0 'False
        Italic = 0 'False
    EndProperty

```

```

    Strikethrough = 0 'False
EndProperty
LinkTopic = "Form1"
MaxButton = 0 'False
ScaleHeight = 4335
ScaleWidth = 6375
StartupPosition = 3 'Windows Default

Begin MSComDlg.CommonDialog CommonDialog1
    Left = 240
    Top = 3600
    _ExtentX = 688
    _ExtentY = 688
    _Version = 393216
End
Begin VB.TextBox Text2
    BeginProperty Font
        Name = "System"
        Size = 9.75
        Charset = 0
        Weight = 700
        Underline = 0 'False
        Italic = 0 'False
        Strikethrough = 0 'False
    EndProperty
    Height = 2052
    Left = 120
    Locked = -1 'True
    MultiLine = -1 'True
    ScrollBars = 2 'Vertical
    TabIndex = 1
    Top = 0
    Width = 6135
End
Begin VB.Timer Timer1
    Left = 720
    Top = 3600
End
Begin MSCommLib.MSComm MSComm1
    Left = 1200
    Top = 3600
    _ExtentX = 794
    _ExtentY = 794
    _Version = 393216
    DTREnable = -1 'True
End
Begin VB.TextBox Text1
    BeginProperty Font
        Name = "System"
        Size = 9.75
        Charset = 0
        Weight = 700
        Underline = 0 'False
        Italic = 0 'False
        Strikethrough = 0 'False
    EndProperty
    Height = 2052
    Left = 120
    MultiLine = -1 'True
    ScrollBars = 2 'Vertical
    TabIndex = 0
    Top = 2160
    Width = 6135
End
Begin VB.Menu mnuFile
    Caption = "&File"
    Begin VB.Menu mnuClear
        Caption = "&Clear"
    End
    Begin VB.Menu mnuAutoSnd
        Caption = "&AutoSend"
    End
    Begin VB.Menu mnuExit
        Caption = "E&xit"
    End
End
End
Attribute VB_Name = "Form1"
Attribute VB_GlobalNameSpace = False
Attribute VB_Creatable = False

```

```

Attribute VB_PredeclaredId = True
Attribute VB_Exposed = False

` V110T05B.FRM, 2002.08.07 @ 08:00 CDT
` See RFM Virtual Wire(r) Development Kit Warranty & License for terms of use
` Experimental software - NO representation is
` made that this software is suitable for any purpose
` Copyright(c) 2000 - 2002, RF Monolithics, Inc.
` For experimental use with the RFM DR1200-DK and DR1201-DK
` and DR1300-DK ASH Transceiver Virtual Wire(R) Development Kits
` For protocol software version DK110K.ASM
` Check www.rfm.com for latest software updates
` Compiled in Microsoft Visual Basic 6.0

` global variables
Dim ASMsg$ ` AutoSend string
Dim ComData$ ` string from com input
Dim ComTime! ` InCom timer
Dim InDel! ` InCom timer delay value
Dim FEND$ ` packet framing character
Dim J As Integer ` FEND$ string position
Dim Q As Integer ` RPkt$ length
Dim RPkt$ ` RX message FIFO string
Dim R2Pkt$ ` RX message display string
Dim KeyIn$ ` keystroke input buffer
Dim Pkt$ ` TX message string
Dim Temp$ ` temp string buffer
Dim N As Integer ` TX message byte counter
Dim TXFlag As Integer ` TX flag
Dim TXCnt As Integer ` TX try counter
Dim TXTO As Integer ` TX timeout counter
Dim ASFlag As Integer ` AutoSend flag

Private Sub Form_Load()

` initialize variables:
ASMsg$ = "12345678901234567890" & vbCrLf
ComData$ = ""
ComTime! = 0
FEND$ = Chr$(192)
J = 1
Q = 0
RPkt$ = ""
R2Pkt$ = ""
KeyIn$ = ""
Pkt$ = ""
Temp$ = ""
N = 0
TXFlag = 0
TXCnt = 0
TXTO = 0
ASFlag = 0

Form1.Left = (Screen.Width - Form1.Width) / 2 ` center form left-right
Form1.Top = (Screen.Height - Form1.Height) / 2 ` center form top-bottom
Text1.BackColor = QBColor(0) ` black background
Text1.ForeColor = QBColor(15) ` white letters
Text1.FontSize = 10 ` 10 point font
Text2.BackColor = QBColor(0) ` black background
Text2.ForeColor = QBColor(15) ` white letters
Text2.FontSize = 10 ` 10 point font

MSComm1.CommPort = 1 ` initialize com port 1
MSComm1.Settings = "19200,N,8,1" ` at 19.2 kbps
MSComm1.RThreshold = 0 ` poll only, no interrupts
MSComm1.InputLen = 0 ` read all characters
MSComm1.PortOpen = True ` open com port
InDel! = 0.1 ` initialize delay at 100 ms

Randomize ` initialize random number generator

Show ` show form
Text1.Text = "***TX Message Window**" & vbCrLf ` display TX start up message
Text1.SelStart = Len(Text1.Text) ` put cursor at end of text
Text2.Text = "***RX Message Window**" & vbCrLf ` display RX start up message
Text2.SelStart = Len(Text2.Text) ` put cursor at end of text

Timer1.Interval = 300 ` 300 ms timer interval
Timer1.Enabled = True ` start timer

End Sub

```

```

Private Sub Timer1_Timer()
    If TXFlag = 1 Then
        Call DoTX
    End If
    If MSComm1.InBufferCount > 0 Then
        Call RxPkt
    End If

    If ASFlag = 1 Then
        Call ASPkt
    End If
End Sub

Public Sub RxPkt()
    Call InCom
    Call ShowPkt
End Sub

Public Sub InCom()
    On Error Resume Next
    ComTime! = Timer
    Do Until Abs(Timer - ComTime!) > InDel!
        Do While MSComm1.InBufferCount > 0
            ComData$ = ComData$ & MSComm1.Input
        Loop
    Loop
End Sub

Public Sub ShowPkt()
    RPkt$ = RPkt$ & ComData$
    ComData$ = ""
    Do
        Q = Len(RPkt$)
        J = InStr(1, RPkt$, FEND$)
        If (J < 2) Then
            RPkt$ = Right$(RPkt$, (Q - J))
        Else
            R2Pkt$ = Left$(RPkt$, (J - 1))
            RPkt$ = Right$(RPkt$, (Q - J))
            If R2Pkt$ <> " ACK" Then
                Call LenTrap
                Text2.SelStart = Len(Text2.Text)
                Text2.SelText = R2Pkt$
                Call SndACK
                R2Pkt$ = ""
            ElseIf R2Pkt$ = " ACK" Then
                Call LenTrap
                Text1.SelStart = Len(Text1.Text)
                Text1.SelText = " <OK> " & vbCrLf
                TXFlag = 0
                TXCnt = 0
                TXTO = 0
                Pkt$ = ""
                R2Pkt$ = ""
            End If
        End If
    Loop Until (J = 0)
End Sub

Private Sub Text1_KeyPress(KeyAscii As Integer)
    If TXFlag = 0 Then
        KeyIn$ = Chr$(KeyAscii)
        If KeyIn$ = Chr$(8) Then
            If N > 0 Then
                Pkt$ = Left$(Pkt$, (N - 1))
                N = N - 1
            End If
        ElseIf KeyIn$ = Chr$(13) Then
            Pkt$ = Pkt$ & vbCrLf
            ASMsg$ = Pkt$
            Pkt$ = FEND$ & Pkt$ & FEND$
            N = 0
            TXFlag = 1
            TXCnt = 0
            TXTO = 0
        Else
            Pkt$ = Pkt$ & KeyIn$
            N = N + 1
        End If
        If (N = 23) Then
            ASMsg$ = Pkt$
        End If
    End If
End Sub

```

```

\ if TX flag set
\ send/resend/NAK

\ if bytes in input buffer
\ call RxPkt

\ if AutoSend flag set
\ call Autosend

\ InCom will get it
\ ShowPkt will show it

\ set up error handler
\ get current time
\ get bytes for InDel! interval
\ while bytes are in com buffer
\ put them in ComData$

\ add ComData$ to end of RPkt$ FIFO
\ clear ComData$ for next time
\ do until FEND$$ gone
\ Q is RPkt$ packet length
\ find position of next FEND$
\ if FEND$ is in the 1st position
\ just delete it
\ else
\ R2Pkt$ what's left of FEND$
\ RPkt$ what's right of FEND$
\ if it's not an ACK
\ manage textbox memory
\ put cursor at end of text
\ show RX message
\ send ACK back
\ and clear R2Pkt$ for the next time
\ if it is an ACK
\ manage textbox memory
\ put cursor at end of text
\ show OK
\ reset TX flag
\ clear TX counter
\ clear TX timeout counter
\ clear TX packet string
\ and clear RPkt$

\ done when there are no more FEND$$

\ if not TX cycle
\ get KeyIn
\ if it's a backspace from keyboard
\ and character counter > 0
\ trim right end of packet
\ back up character counter

\ else if it's a Cr
\ add vbCrLf
\ update AutoSend message
\ add framing FEND$
\ reset N
\ set TX flag
\ clear TX try counter
\ clear TX timeout counter

\ else add character to TX message
\ increment character counter

\ if character count 23
\ update AutoSend message

```

```

        Pkt$ = FEND$ & Pkt$ & FEND$           ` add packet framing characters
        N = 0                                 ` reset N
        TXFlag = 1                            ` set TX flag
        TXCnt = 0                             ` clear TX try counter
        TXTO = 0                              ` clear TX timeout counter
    End If
    Call LenTrap                              ` manage textbox memory
Else
    KeyAscii = 0                             ` else don't echo to the screen
End If
End Sub

Public Sub DoTX()
    If TXTO = 0 Then                          ` if TX timeout zero
        TXCnt = TXCnt + 1                    ` increment TX try counter
        If TXCnt = 1 Then                    ` if TX try count 1
            Call SndPkt                      ` send packet
            TXTO = 4                          ` set 0.8 second timeout
        ElseIf (TXCnt > 1) And (TXCnt < 7) Then ` for try counts 2 through 6
            Call SndPkt                      ` send packet
            TXTO = 4 + Int(8 * Rnd)          ` load random TX timeout count
        ElseIf TXCnt >= 7 Then               ` else if past 6th try
            Call LenTrap                    ` manage textbox memory
            Text1.SelStart = Len(Text1.Text) ` put cursor at end of text
            Text1.SelText = " <NAK>" & vbCrLf ` show NAK
            TXFlag = 0                       ` reset TX flag
            TCnt = 0                         ` clear TX counter
            TXTO = 0                         ` clear TX timeout counter
            Pkt$ = ""                        ` clear TX packet string
            R2Pkt$ = ""                      ` clear RPkt$
        End If
    Else
        TXTO = TXTO - 1                      ` else if TX timeout counter not 0
    End If
    ` decrement it one count
End Sub

Public Sub SndPkt()
    If Pkt$ <> "" Then                       ` if Pkt$ not null
        MSComm1.Output = Pkt$               ` send packet
    End If
End Sub

Public Sub ASPkt()
    If TXFlag = 0 Then                       ` if TXFlag not set
        Temp$ = ASMsg$                      ` use Temp$ for local display
        Call LenTrap                        ` manage textbox memory
        Text1.SelStart = Len(Text1.Text)    ` put cursor at end of text
        Text1.SelText = Temp$              ` add message to textbox
        Pkt$ = FEND$ & ASMsg$ & FEND$      ` add packet framing to message
        TXFlag = 1                          ` set ACK flag
        TXCnt = 0                           ` clear TX try counter
        TXTO = 0                            ` clear TX timeout counter
    End If
End Sub

Public Sub SndACK()
    MSComm1.Output = FEND$ & " ACK" & FEND$ ` send ACK back
End Sub

Public Sub LenTrap()
    If Len(Text1.Text) > 16000 Then          ` manage textbox memory
        Text1.Text = ""                    ` clear TX textbox
        Text1.SelStart = Len(Text1.Text)    ` put cursor at end of text
    End If
    If Len(Text2.Text) > 16000 Then         ` manage textbox memory
        Text2.Text = ""                   ` clear RX textbox
        Text2.SelStart = Len(Text2.Text)   ` put cursor at end of text
    End If
End Sub

Private Sub Form_Unload(Cancel As Integer)
    MSComm1.PortOpen = False              ` close com port
End Sub
` done!

Private Sub mnuAutoSnd_Click()
    ASFlag = ASFlag Xor 1                  ` toggle AutoSend flag
    If ASFlag = 0 Then                     ` if flag reset
        mnuAutoSnd.Checked = False        ` uncheck AutoSend
        Text1.ForeColor = QBColor(15)     ` white characters
    End If
End Sub

```

```

Else
    mnuAutoSnd.Checked = True
    Text1.ForeColor = QBColor(10)
End If
End Sub

Private Sub mnuClear_Click()
    Text1.Text = ""
    Text1.SelStart = Len(Text1.Text)
    Text2.Text = ""
    Text2.SelStart = Len(Text2.Text)
End Sub

Private Sub mnuExit_Click()
    MSComm1.PortOpen = False
End
End Sub

```

\ else
 \ check AutoSend
 \ green characters

 \ clear TX textbox
 \ put cursor at end of text
 \ clear RX textbox
 \ put cursor at end of text

 \ close com port
 \ done!

6 Revisions and Disclaimers

There are several improvements in the example software in this revision. The RF data rate in both link layer protocol examples has been increased from 1200 to 2000 bps, and the packet retry back off interval in DK200A.ASM has been better randomized. The V110T30C host terminal program now supports multi-packet messages and both host terminal programs provide better Windows efficiency. Component values in Figure 4.2 have been adjusted to match the higher RF data rate.

The information in this design guide is for tutorial purposes only. Any software developed using the information provided in this guide should be thoroughly tested before use. No representation is made that the software techniques and example code documented in this guide will work in any specific application. Please refer to the Virtual Wire® Development Kit Software License and Warranty for additional information.

RFM and Virtual Wire are registered trademarks of RF Monolithics, Inc. MS-DOS, QuickBASIC, Visual Basic and Windows are registered trademarks of Microsoft Corporation. Keyloq is a trademark of Microchip, Inc.

file: tr_swg19.vp, 2002.08.07