

ADVANCES IN SAW TECHNOLOGY

DARRELL L. ASH
RF MONOLITHICS, INC., DALLAS, TEXAS

INTRODUCTION

In today's wireless world, going wireless is associated with eliminating cumbersome wires and cables, making it possible to roam with fully operational systems. There are three basic wireless requirements in today's market. The first is represented by cellular phone systems which have a relatively long range of a few kilometers. The second is represented, for example, by two intermediate range unlicensed systems, spread spectrum systems and narrow band systems. These systems have a typical range of over 300 meters, achieved by higher transmitter power (up to 1 watt) for spread spectrum links, and greater receiver sensitivity (-115 to -110 dBm) for narrow band links. The third is the short range unlicensed system that has a typical range of from 1 to 100 meters. The variety of applications for short range wireless systems far surpasses that of the long and intermediate range systems. Short range applications include automotive keyless entry, garage door and gate openers, wireless security systems, data links, wireless barcode readers, electronic personal ID, remote meter reading, animal tagging, in-house arrest systems, wireless keyboards, wireless mice and wireless joysticks. This paper addresses the third category, short range wireless systems.

Some of the desired attributes of the receivers and transmitters used in these systems include low cost, very low power consumption, miniature size, no adjustments, good frequency stability, good range, the ability to operate in a crowded frequency spectrum and ease of application by engineers with limited RF training. One of the more stringent applications requires a receiver and a transmitter to be included in a small wristwatch; hence, the miniature size requirement. As exemplified by the wristwatch requirement, more and more of the short range applications are requiring two-way links. This paper discusses an approach that makes use of the latest SAW technology to meet all of these requirements.

CURRENT TRANSMITTER AND RECEIVER TECHNOLOGIES

Transmitters

Current low power transmitters primarily include either SAW stabilized oscillators or crystal stabilized frequency synthesizers. Crystal stabilized frequency synthesizers have greater frequency accuracy than SAW transmitters but consume more power, have more spurious frequencies, are physically larger and cost more than SAW stabilized transmitters. The bulk crystals used as the frequency reference for such synthesizers are also very fragile and frequently break when subjected to drops on concrete etc. SAW based transmitters are very rugged, in comparison. Cost, power consumption, size and ruggedness are the most critical requirements for SRD transmitters. The additional cost, power consumption, fragility and size of frequency synthesizers are only justified if the system utilizes a narrow band receiver that requires the additional frequency accuracy.

Receivers

The most popular current receiver technologies are the superregenerative, superheterodyne and amplifier sequenced hybrid (ASH) receivers. The inductor/capacitor (LC) based superregenerative receivers are rapidly being replaced by the other two receiver technologies due to poor frequency stability, reliability and out-of-band rejection of unwanted signals. Desirable attributes of the superregenerative receiver are its very low power consumption and low cost.

Superheterodyne Receiver

Figure 1 is a block diagram of a simple, single-conversion superheterodyne receiver. This receiver achieves the stable gain necessary to achieve high sensitivity through simple frequency diversity. Since the

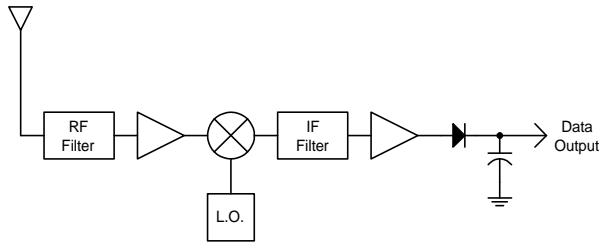

Figure 1
Superheterodyne Receiver

RF and IF amplifiers are not at the same frequency, feedback from the IF amplifier output to the RF amplifier input does not cause a stability problem. Even more stable gain can be added by increasing the number of conversions or IF's. In addition, more rejection of unwanted signals is achieved by splitting the filtering between RF and IF filters, thus eliminating the crosstalk that occurs when filters are cascaded at the same frequency. As a result, this receiver architecture achieves good

sensitivity and good out-of-band rejection. If the RF filter is wide enough, or is tunable, the reception frequency of this receiver can be changed by varying the local oscillator frequency. A disadvantage of this is frequency selectivity in the RF filter must be compromised to allow frequency agility. Other disadvantages are relatively large physical size, high power consumption, the need for a stable local oscillator, oscillator radiation, mixer spurious responses (especially the image frequency) and critical circuit board layout. The relatively large physical size is due to the need for either a SAW device or a crystal to stabilize the local oscillator, a SAW or other technology for an RF filter and a SAW, ceramic or LC IF filter. Due to the relatively low frequency of the IF filter, it can be quite large. The high power consumption is primarily due to the need for the local oscillator to develop an RF level high enough to drive the mixer into non-linearity while minimizing intermodulation and cross-modulation distortion in the mixer.

Amplifier Sequenced Hybrid Receiver

The amplifier sequenced hybrid receiver was introduced by RFM in 1995. Figure 2 is a simplified block diagram of this receiver architecture. This receiver achieves the stable gain necessary to obtain high sensitivity through time diversity. The high gain RF amplifiers, on each side of the SAW delay line, are turned on and off by a pulse generator. When one amplifier is on, the other is off and vice versa. Since the two amplifiers are not on at the same time, feedback from one amplifier to the other does not cause the circuit to become unstable. The delay line serves as a storage element, supplying signal to the second amplifier while the first amplifier is off. Filtering in this receiver is provided by both the SAW bandpass filter and the SAW delay line. Normally, two filters at the same frequency would be limited in out-of-band rejection to much less than the resultant cascaded 100 dB by the crosstalk level that could be achieved with a particular circuit layout. However, crosstalk around the delay line filter is effectively gated out by the switching of the amplifiers. Crosstalk around the SAW bandpass filter is effectively eliminated by providing a single-ended connection to the antenna and a differential connection to the RF amplifier, taking advantage of common-mode rejection. The result is a receiver with sensitivity and frequency selectivity similar to a super-heterodyne receiver.

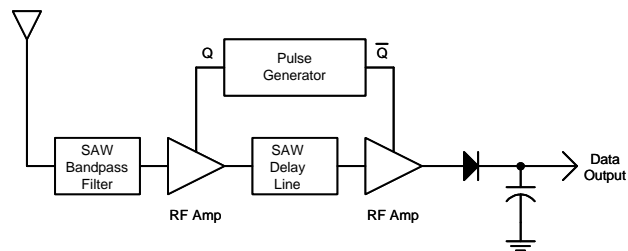

Figure 2
ASH Receiver Simplified Block Diagram

The ASH receiver architecture has several advantages over previous architectures. All of the functions, except the two SAW devices, are included in a single custom integrated circuit. Since the SAW devices are at RF rather than a low IF, they are extremely small in size. This makes it possible to include the entire receiver in a small hybrid package. No adjustments are needed since the frequency of the receiver is entirely determined by the two SAW devices. No RF oscillators are needed which completely eliminates concerns about LO radiation, mixer spurious responses and the associated DC power consumption. Since

the RF amplifiers consume more power than the rest of the active circuitry, the switching of these amplifiers further reduces the overall power consumption by at least 50%.

Figure 3 is a functional block diagram of the ASH receiver including the custom IC, SAW devices, various control resistors and baseband coupling capacitor. The diagram also shows the gain and loss values for the signal path. The output of the second RF amplifier drives a square law detector realized using a Gilbert cell. The IC includes a post-detection 3 pole low pass filter whose bandwidth is controlled by a single resistor, RFIL. The output of the low pass filter is capacitively coupled to a data slicer with a fixed threshold. The output of the data slicer is capable of driving a single CMOS gate.

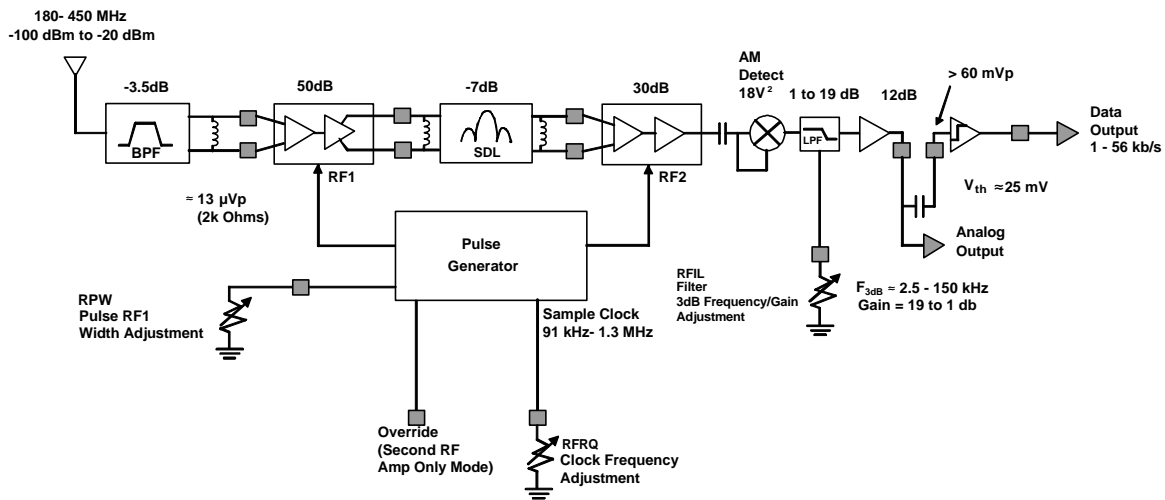

Figure 3
ASH Receiver Functional Block Diagram

NEW SAW-BASED HYBRID TRANSCEIVER

Requirements

The development of a small hybrid transceiver was driven by the market requirement for short range wireless data links with two-way communication capability. Other requirements included smaller size than the present RFM hybrid receiver and transmitter; lower cost than using separate receiver and transmitter modules; data rates up to 115 kb/s; full receiver sensitivity from 300 to 1000 MHz; a much higher in-band RF saturation level than the present receiver; low current consumption; the capability to work with either OOK or ASK (amplitude shift keyed) modulation and allowing the customer to have access to pulse generator, low pass filter bandwidth, threshold and transmitter power controls. Since the superheterodyne architecture did not fit the size and current requirements for the receiver and it was considered to be more difficult to realize a superheterodyne based transceiver using components in common with both receive and transmit functions, the decision was made to use the ASH receiver architecture.

Transceiver Realization

Figure 4 is the block diagram of the resultant transceiver. The same two SAW devices utilized in the ASH receiver were used for the transmitter function. Referring to Figure 4, this was accomplished by adding a pair of amplifiers to the custom IC, TXA1 and TXA2, that are turned on in the transmit mode. TXA1 and the SAW delay line used in the receiver form the transmitter oscillator, TXA2 is the transmitter output amplifier and the receiver's input SAW coupled resonator bandpass filter acts as the harmonic filter on the transmitter output. The RF amplifiers in the receiver, RFA1 and RFA2, are disabled in the transmit mode.

The Q of the delay line allows the new transmitter to be OOK modulated up to 38 kb/s with a typical rise time of 7 to 8 us. For higher data rates, ASK modulation is used. This is accomplished by leaving the oscillator amplifier, TXA1, on while modulating TXA2. The typical rise time for the modulated transmitter output, in the ASK mode, is less than 1 us. The transmitter modulation input was designed to allow quasi-linear modulation of the transmitter amplitude. Thus, the modulation sidebands of the transmitter's RF output can be controlled by shaping the data input to the modulator. This allows fitting the modulated transmitter into a restricted bandwidth. By the same means, the power output of the transmitter can be controlled by the value of the user accessible resistor, Rtxm, in series with the modulation input port. Thus, the ASH receiver architecture was very easy to convert to a transceiver by reusing the same two SAW devices utilized in the receiver to stabilize the center frequency and provide harmonic filtering in the transmitter. Since the same IC provides both the transmit and receive functions and both functions share the same SAW devices, both the size and cost of the new transceiver have been minimized.

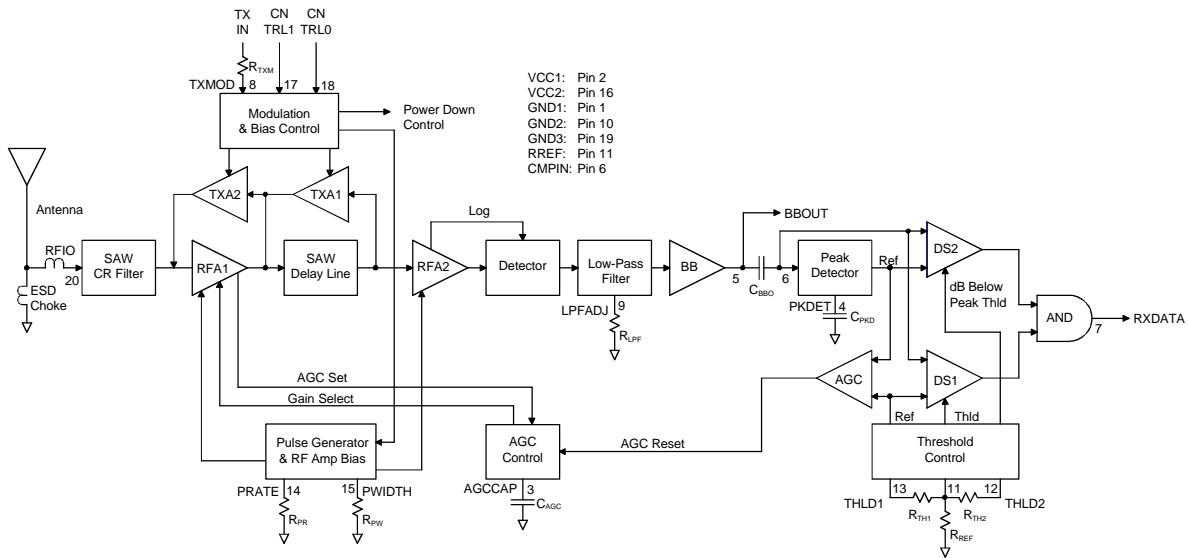

Figure 4
ASH Transceiver Block Diagram

The RF amplifiers in the new custom IC were designed to have a 3 dB bandwidth exceeding 1000 MHz to make it possible to have full receiver sensitivity from 300 to 1000 MHz. In order to increase the RF saturation level of the receiver in the new transceiver, it was necessary to make three changes to the original ASH receiver.

Referring to Figures 3 and 4, the first change was in the detector. The first receiver uses a single square law detector following the second RF amplifier. This detector saturates at a receiver input level of -80 dBm. This problem was addressed in the transceiver by using distributed detection along the entire second amplifier, simulating a logarithmic detector. A modified Gilbert cell detector was also used at the output of the last amplifier. The outputs of all of these detectors were then summed together and fed into a 3 pole gyrator low pass filter. Thus, as each of the detectors reach saturation level, the outputs of the previous detectors still function. Figure 5 is a plot of the RF input level at the input to RFA1 versus the detected level at the baseband output. Note that the horizontal axis is in dBm while the vertical axis is linear, so the plot indicates a very close approximation to a logarithmic detector.

The second change was in the receiver's gain distribution. The gain in the first RF amplifier, RFA1, was decreased from 50 dB, in the original receiver, to 35 dB, and the gain in the second amplifier, RFA2, was increased from 30 dB to 50 dB. This change improved the receiver in two areas. The gain increase of 20 dB in RFA2 increased the log detector range by 20 dB over what could be obtained with a 30 dB gain

block, and the gain decrease of 15 dB in RFA1 increased the RF input level that could be handled without saturation by 15 dB, at the delay line input.

The third change was to include an optional AGC system in the new transceiver. The user can choose to either enable or disable the AGC function. Referring to Figure 4, a simple stepped AGC was included. When the output level of the final stage of RFA1 is one to two dB into compression, it sets a flip-flop in the AGC control circuit that changes the gain of RFA1 from 35 dB to 5 dB. This increases the RF input level required to saturate the receiver from -45 dBm to -15 dBm. The AGC circuit resets RFA1 back to full gain when the detected signal level multiplied by 0.8 in the baseband circuit drops below the threshold reference for the “fixed” reference data comparator.

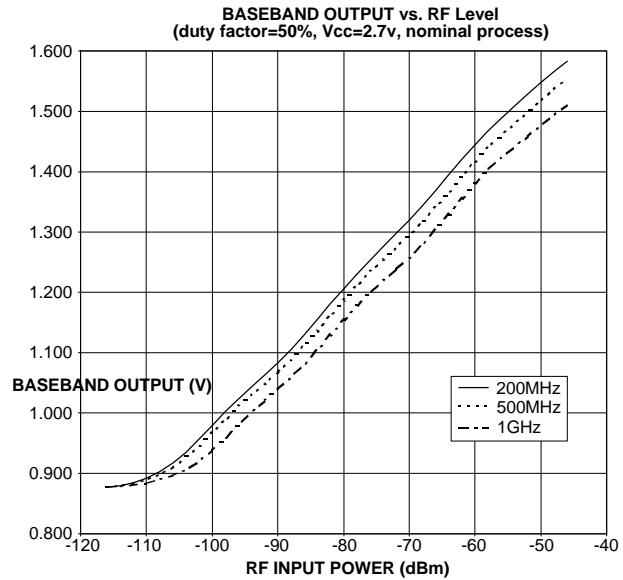

Figure 5
Transceiver RF Input vs Detected Output

The ability of the new transceiver to work with ASK modulation can be used to greatly reduce the adverse effects of a high level amplitude modulated, in-band interfering signal. The modulation from such an interfering signal appears during the “carrier off” condition with OOK modulation, but is masked when using ASK, since the desired RF carrier is present for all data conditions.

At higher data rates, it is also highly desirable that distortion in an ASK signal due to frequency band-limiting, by either filters in the receiver or in the transmitter, does not prevent slicing the detected signal at the correct level to get good data reproduction at the output of the data comparator. The logarithmic detector can make band-limiting distortion even worse. Referring to Figure 4, this type of distortion is handled very well in the new receiver with the addition of data slicer, DS2, whose threshold is positioned approximately 6 dB below the peak of the detected pulse. This is accomplished by using a peak detector to find the top of the pulse and offsetting the threshold by 6 dB using the slope of the logarithmic detector to determine the correct DC offset from the peak. The output of DS2 and the output of the fixed reference comparator, DS1, drive the input to an AND gate. Both comparator outputs must be high before the gate outputs a high. This prevents noise spikes from either of the comparators from appearing at the receiver output unless both comparators see them. Once again, the user can either enable or disable the peak detector referenced comparator.

Finally, to address the issue of low current consumption, first, the sequencing of the RF amplifiers in the ASH receiver architecture reduces the current consumption by at least 50%. At low data rates, the current consumption can be reduced even further by reducing the duty cycle of the RF amplifiers below 50%. This is accomplished by decreasing the pulse rate in the pulse generator while maintaining the same pulse width. Second, the new transceiver was designed to have a “power down” mode that is invoked by pulling the CNTRL1 and CNTRL0 ports to a CMOS low, see Figure 4. If this mode is used, the receiver can be periodically turned on to see if a recognizable wake-up code is being transmitted. An example would be turning the receiver on for 10 ms every second. This would reduce the average current consumption of the receiver by a factor of 100. The new receiver typically consumes 1.6 ma of current when set up for a 2.4 kb/s data rate; thus, a reduction by a factor of 100 would reduce the average current to 15 microamps. This makes the transceiver useable in watch or ID card applications using lithium coin cell batteries.

Transceiver Performance and Characteristics

The performance of the resulting transceiver with a data rate of 2.4 kb/s is included in Table I. The surface mount package dimensions for a complete 868 MHz transceiver are 10.2 X 7.06 X 2.03 mm. The case

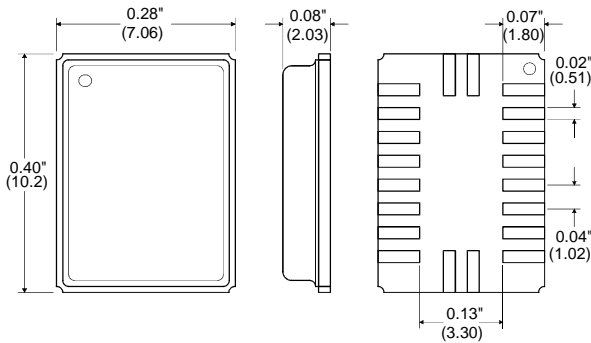

Figure 6
ASH Transceiver Outline Drawing

outline drawings for the new hermetic package are shown in Figure 6. Figure 7 includes a package outline, simplified block diagram, required external components and external electrical connections for the hybrid transceiver. The components and connections of Figure 7 make use of every available option. The small size and current consumption of the device make it ideal for applications such as the watch example given.

TABLE I
ASH Transceiver Performance Example

	RECEIVER	
Data Rate	2.4 kb/s	
Sensitivity	-102 dBm	(50% sampling)
Sensitivity	-97 dBm	(12.5% sampling)
Out-of-band rejection	100 dB	
RF Bandwidth	500 kHz	(minimum)
Max Signal	0 dBm	
Det Saturation	-45 dBm	
Det Sat w/AGC	-15 dBm	
DC Voltage	2.4 to 3.5 volts	
DC Current	3.0 mA	(50% sampling)
DC Current	1.6 mA	(12.5% sampling)
	TRANSMITTER	
Power Output	0 dBm	
DC Voltage	2.4 to 3.5 volts	
DC Current	10 mA peak	
Operating Temperature	-40 to +85 degrees C	

TRANSCEIVER PERFORMANCE VERSUS TETRA/ETSI REQUIREMENTS

The frequency spectrum is becoming more and more crowded, as evidenced by the recent problems caused by introducing the new TETRA (Trans European Trunked Radio) service in the U.K. The problem in the U.K. was compounded by the presence of a narrow 418 MHz low power band, located between the TETRA mobile frequencies and the TETRA base station frequencies, that is primarily used for automotive keyless entry. The manufacturers of the receivers used in this low power application did not anticipate the introduction of such a service, so the receivers were ill equipped to deal with the interference potential of the TETRA system. Many were LC stabilized superregenerative receivers with their inherent poor frequency selectivity. Earlier this year, superheterodyne receivers equipped with SAW coupled resonator RF front-end filters were shown to the Radiocommunications Agency that demonstrated more than acceptable performance in the presence of simulated TETRA signals.

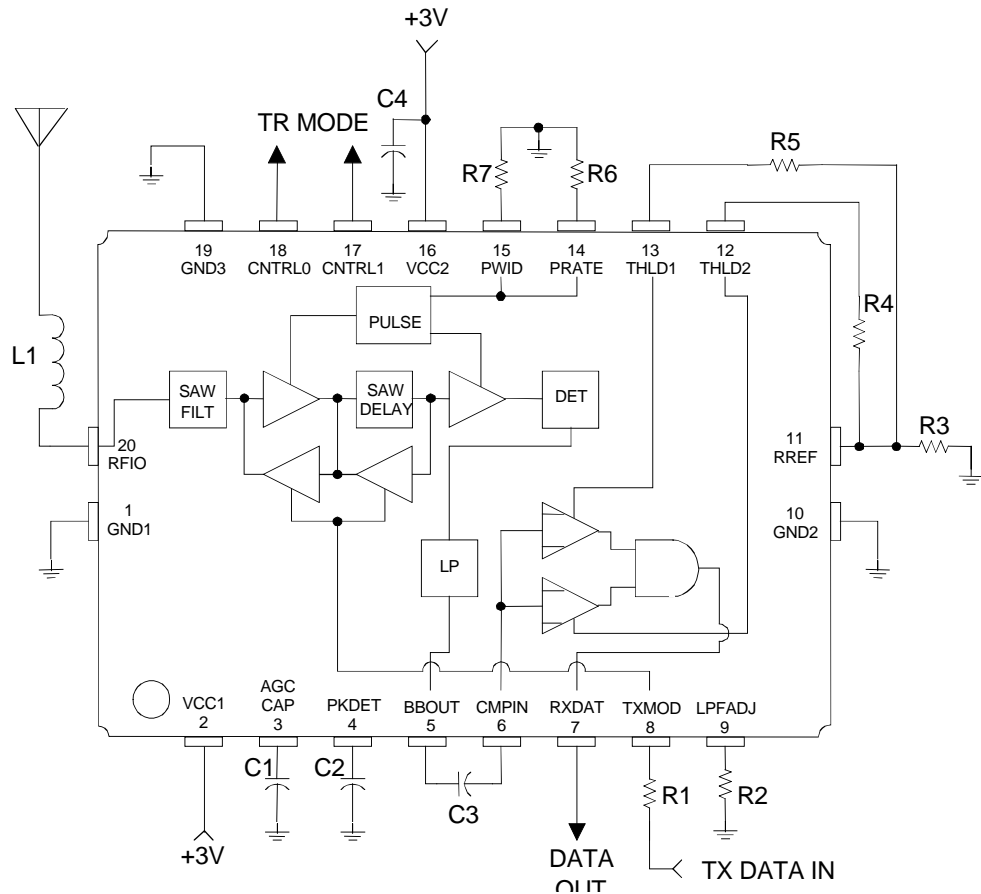

Figure 7
ASH Transceiver Electrical Connections

Proposed ETSI Requirements

The new 868 to 870 MHz SRD band has been a topic of much discussion in light of the TETRA interference problems encountered in the 400 MHz band. As a result, the remainder of this paper will focus on the 868 MHz version of the SAW based transceiver discussed earlier. ETSI, in conjunction with industry, is presently working very hard to rewrite EN 300 220-1 to include more stringent specifications on SRD transmitters and receivers. For example, the present draft includes a transmitter maximum frequency drift specification of ± 100 ppm under the extreme voltage and temperature conditions of that document. This can be met with SAW based equipment, including the new transceiver. In the area of SRD receivers, a blocking or desensitization specification has been added. For Class 1 equipment, whose low performance or failure would result in physical risk to persons, the blocking ratio between the desired in-band signal and an interfering out-of-band signal is specified to be 84 dB, starting at a 1 MHz frequency offset. For Class 2 equipment, whose low performance would result in an inconvenience to persons that cannot simply be overcome by other means, the blocking ratio is specified to be 30 dB at 1 MHz, 35 dB at 2 MHz, 50 dB at 5 MHz and 60 dB at 10 MHz frequency offset. For Class 3 equipment, whose low performance would result in an inconvenience to persons which can simply be overcome by other means, no blocking performance is specified.

Present Transceiver

The present 868 MHz transceiver product, the TR1001, utilizes a SAW coupled resonator for the front end RF bandpass filter whose frequency response is shown in Figure 8. This filter is a 2 pole structure with a bandwidth of approximately 700 KHz and a center frequency of 868.35 MHz. The filter ultimately reaches >60 dB of rejection, but, as can be seen in Figure 8, the device has close-in spurious responses that definitely affect the receiver's blocking performance at the frequency offsets of 2, 5 and 10 MHz. The rejection of the coupled resonator at the +/-1 MHz points is limited by the 12 dB/octave roll off rate, characteristic of a two pole filter. The bandwidth of the SAW delay line second filter in the receiver is 1.5 MHz and the filter response is very close to that of a 6 pole linear phase Bessel filter. As a result, the coupled resonator filter must provide the majority of the receiver selectivity needed to meet the blocking requirement. The rejection of the coupled resonator filter, derived from the plot of Figure 8, is shown in Table II for each of the specified frequency offsets versus the Class 2 proposed blocking ratio specifications. Note that this filter does not meet the proposed blocking requirements for a Class 2 system. Thus, the present receiver would be suitable for Class 3 equipment but not Class 2 with the proposed blocking requirement.

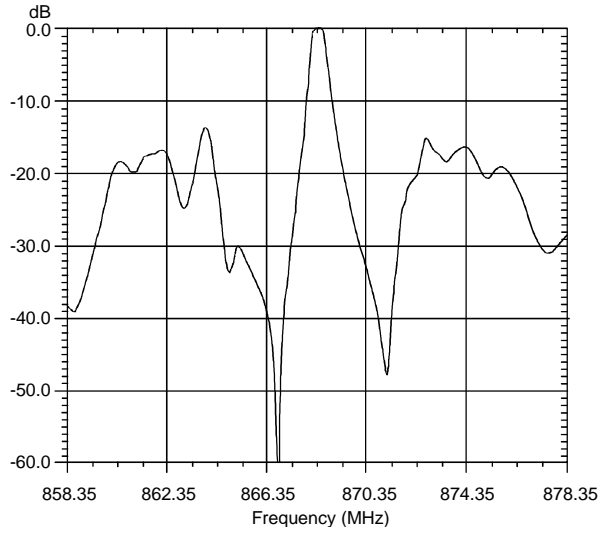

Figure 8
Present SAW Coupled Resonator Filter

TABLE II
SAW Coupled Resonator Rejection Versus Proposed Class 2 Blocking Ratio

CR Filter	+1 MHz 19 dB	+2 MHz 33 dB	+5 MHz 18 dB	+10 MHz 29 dB
CR Filter	-1 MHz 30 dB	-2 MHz 38 dB	- 5 MHz 23 dB	-10 MHz 38 dB
ETSI Spec	30 dB	35 dB	50 dB	60 dB

Proposed New Transceiver Filter

A new 868 MHz SAW coupled resonator filter is being designed for the transceiver that would meet the proposed blocking requirements for Class 2 equipment. The form factor, for the upgraded transceiver, would be the same as for the present device. The frequency response of the new filter is shown in Figure 9. The new coupled resonator filter is a 4 pole device with a typical bandwidth of 620 KHz and a center frequency of 868.35 MHz. This bandwidth accounts for the temperature variations of the transmitter and receiver as well as the data modulation side bands. The ultimate rejection is approximately 70 dB, and the close-in spurious responses of the present filter have been eliminated. The rejection of the new

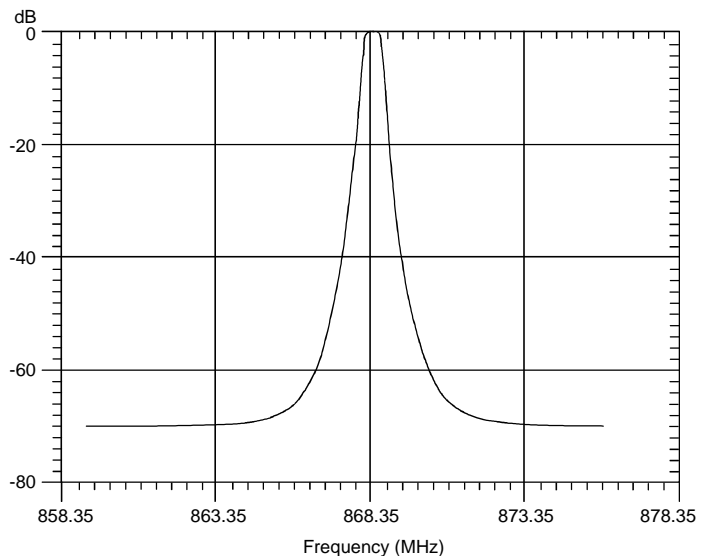

Figure 9
New SAW Coupled Resonator Filter

filter, derived from the plot of Figure 9, is shown in Table III for each of the Class 2 frequency offset points. Note that the new filter provides the needed selectivity to meet the proposed blocking ratios. The ultimate out-of-band rejection of the entire transceiver (>100 dB) will be approximately the same as that obtained using the present filter, but the close-in spurious responses will be eliminated by the new filter.

TABLE III
New SAW Coupled Resonator Filter Rejection Versus Proposed Class 2 Blocking Ratio

New CR	+/-1 MHz 42 dB	+/-2 MHz 62 dB	+/-5 MHz 70 dB	+/-10 MHz 70 dB
ETSI Spec	30 dB	35 dB	50 dB	60 dB

CONCLUSION

A new transceiver has been designed around the capability of SAW devices. The delay of a SAW delay line was used as a storage element to create a time diversity receiver while using its amplitude characteristics to perform a filtering function. The same delay line's phase characteristics were then used to create the transmitter oscillator. On the antenna port, a SAW coupled resonator filter was used as a preselector filter on the receiver input, and it was used to filter out harmonics on the output of the transmitter. The use of the same two SAW devices in both the receiver and the transmitter, in conjunction with a custom IC for the active functions, made it possible to include the entire transceiver in a 10.2 X 7.06 X 2.03 mm surface mount package. This small size in combination with low power consumption, low cost and excellent radio data link performance make the new transceiver ideal for wireless SRD applications involving watches, ID cards, hand-held apparatus, computers, computer peripherals, tags and many more applications.

The compatibility of the new transceiver with the industry/ETSI proposed SRD requirements in the new EN 300 220-1 document has been discussed. The transceiver is already compatible with the proposed requirements for Class 3 equipment. A new 868 MHz SAW filter has been discussed that will make it possible to meet the proposed blocking requirements for Class 2 equipment. This filter would simply replace the present front-end SAW filter in the transceiver while maintaining the same small form factor.

ACKNOWLEDGEMENT

The author would like to thank Darren Ash for his invaluable assistance in putting this paper together.